

FIXED FURNITURE DETAILS: WORKTOP WITH SS SURFACE

1. Worktop 32 mm thick hardwood to specification.
2. 1.5 mm removable stainless steel sheet covering top and sides of worktop with all corners welded, front corners rounded.
3. 25 x 25 mm square hollow section frame and legs with adjustable feet. All with powder coated finish in selected RAL colour.
4. 50 x 25 mm SW batten fixed to wall and steel frame.

Minimum Standards for materials and finishes:

Core material for worktops, doors and carcasses:
 Dry Fibre Board (MDF) to I.S. EN 622-5 Class E1 formaldehyde content tested to EN 120.
 Moisture resistant board to I.S. EN 622-5 MDF:H, class E1 formaldehyde content tested to EN 120.

Core materials to be finished with plastic laminates to comply with I.S. EN 438, grade HGS/HGP (including vertical panels, shelves and doors).
 Balancing laminate to be used in all cases.

Edges of all laminated panels (if not postformed) to be finished with solid colour laminate (2 mm thickness), PVC or hardwood edges to seal all edges.

Solid timber to comply with IS EN 942, Class J10.
 FSC/PEFC chain of custody certification required for all timber and timber products, including MDF.

Metal frames:
 Generally 60x30 mm mild steel frame with welded end caps and adjustable feet. Epoxy powder coated to selected RAL colour.

Ironmongery:
 Stainless steel door handles, reversed fixed through doors. High quality stainless steel or nickel plated self-closing hinges (180°) and high quality cylinder style lock on masterkey system to suit the school's requirements.

Hardwood plinth size to be coordinated with skirting height in rooms.

Note:
 Alternative materials and finishes of equal or higher specification and performance are permitted.
 Drawings to be read in conjunction with specification.

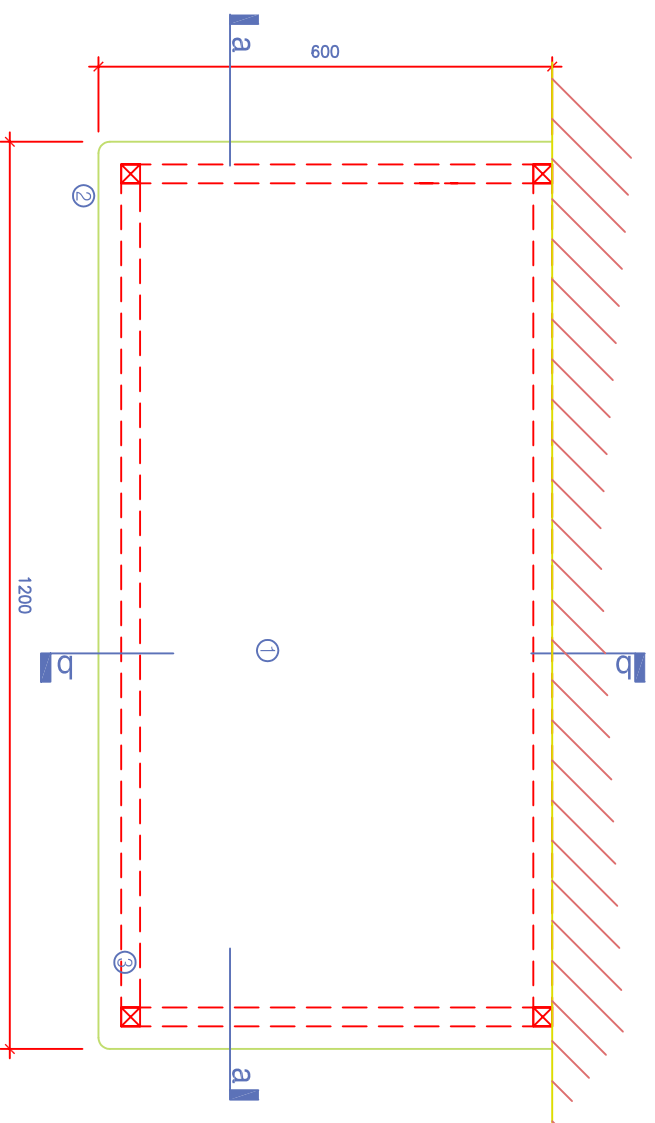

plan

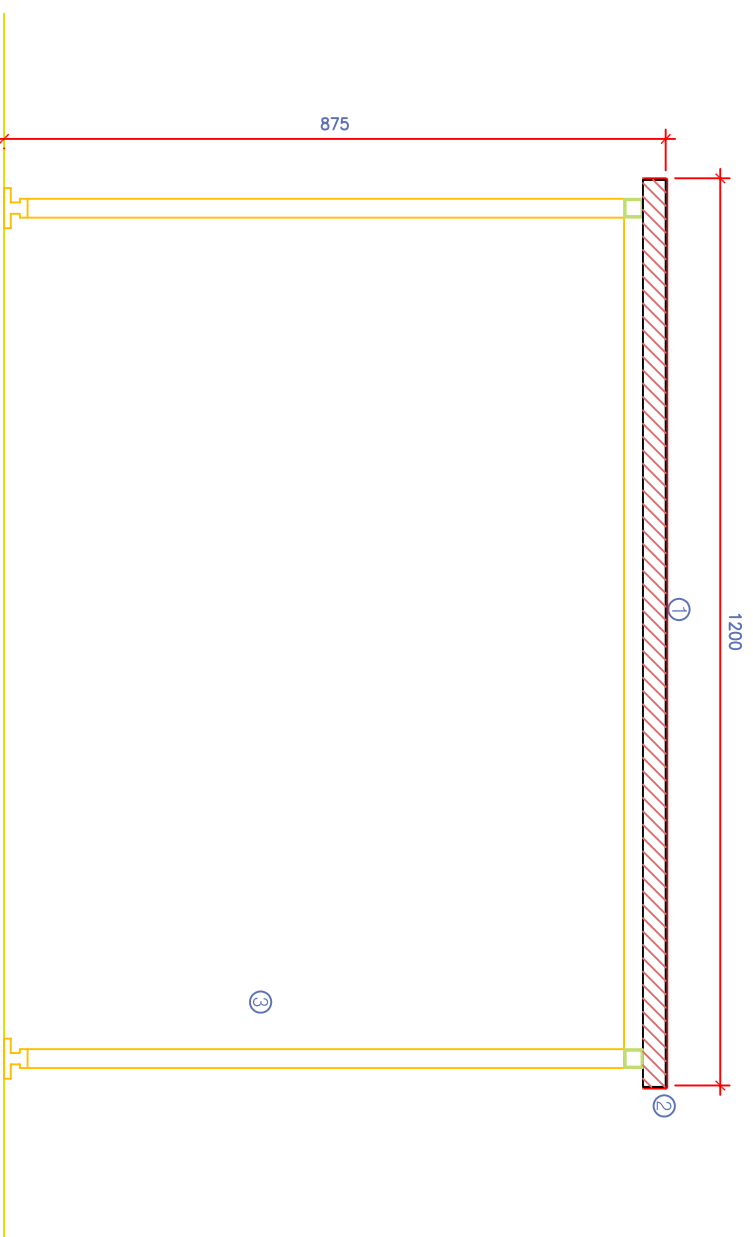

section a-a

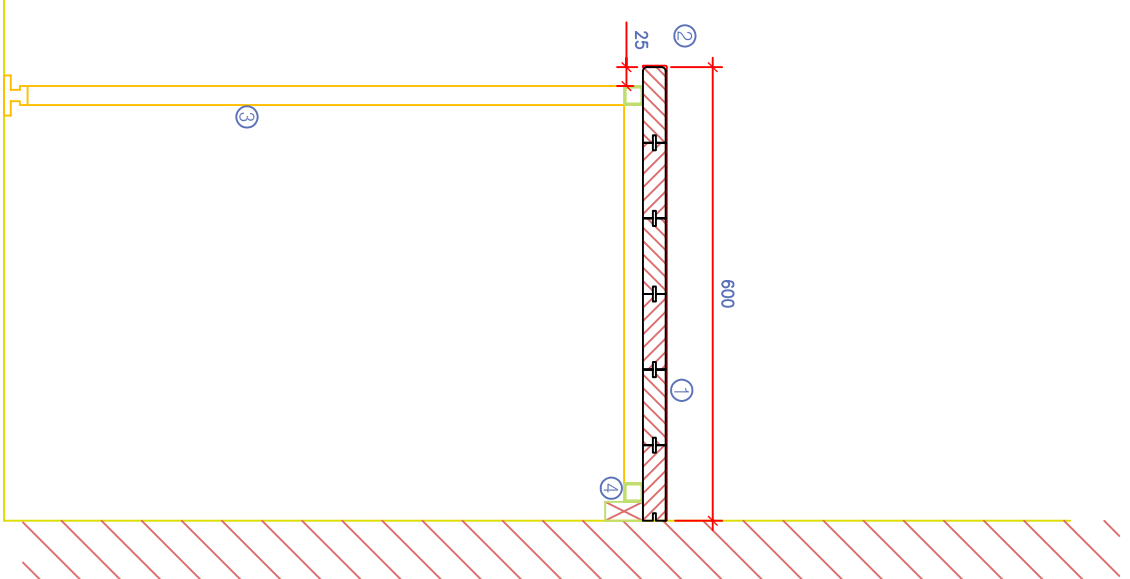

section b-b

**ART & CRAFT WORKTOP WITH
 SS SURFACE - WTA**

SCALE:	1:10
DRG No:	032
DATE:	JUNE '10
CHECKED BY :	-
PREPARED BY:	-

