

Notes:
 Do not scale from this drawing.
 Use figured dimensions only.
 All errors and omissions to be reported to the Architect.
 This drawing to be read in conjunction with relevant consultant's drawings.
 All dimensions are in millimetres and all levels are in meters to match Datum unless otherwise noted.

Contractor Design Responsibility
 It is noted that there are many elements within the works that require contractor design, and will be subject to certification as part of BCAR - see Preliminary Inspection Plan for clarity on certification required.

© This drawing or design may not be reproduced without permission.

Legend

WG001	Window / External Door reference tag
--- CJ	Control Joint
--- MJ	Movement Joint
--- CB	Cavity Barrier
---	30/15 rated cavity barrier / closer

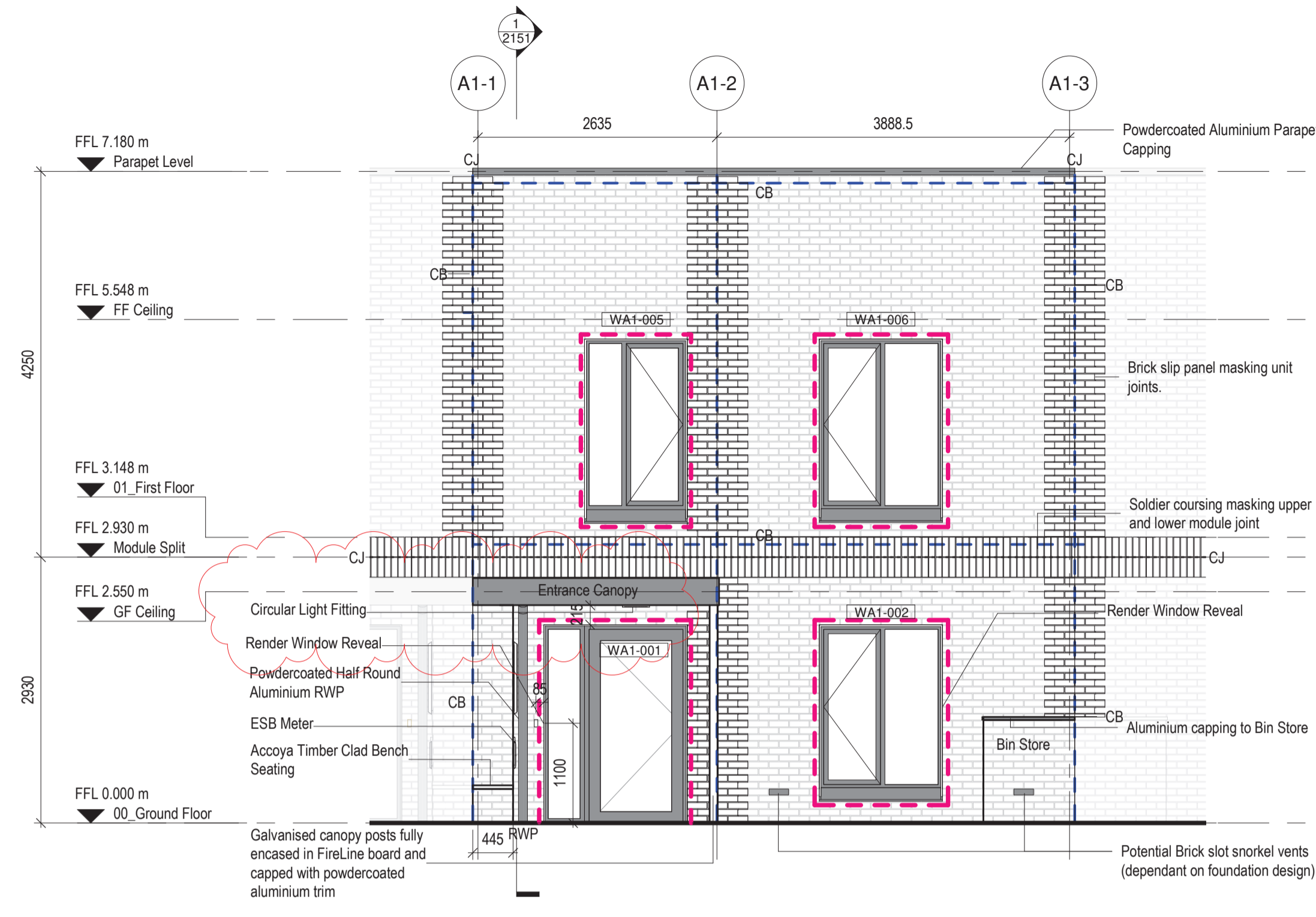

A1-F ELE-TYP-A1-FRONT ELEVATION-MID TERRACE
1:50

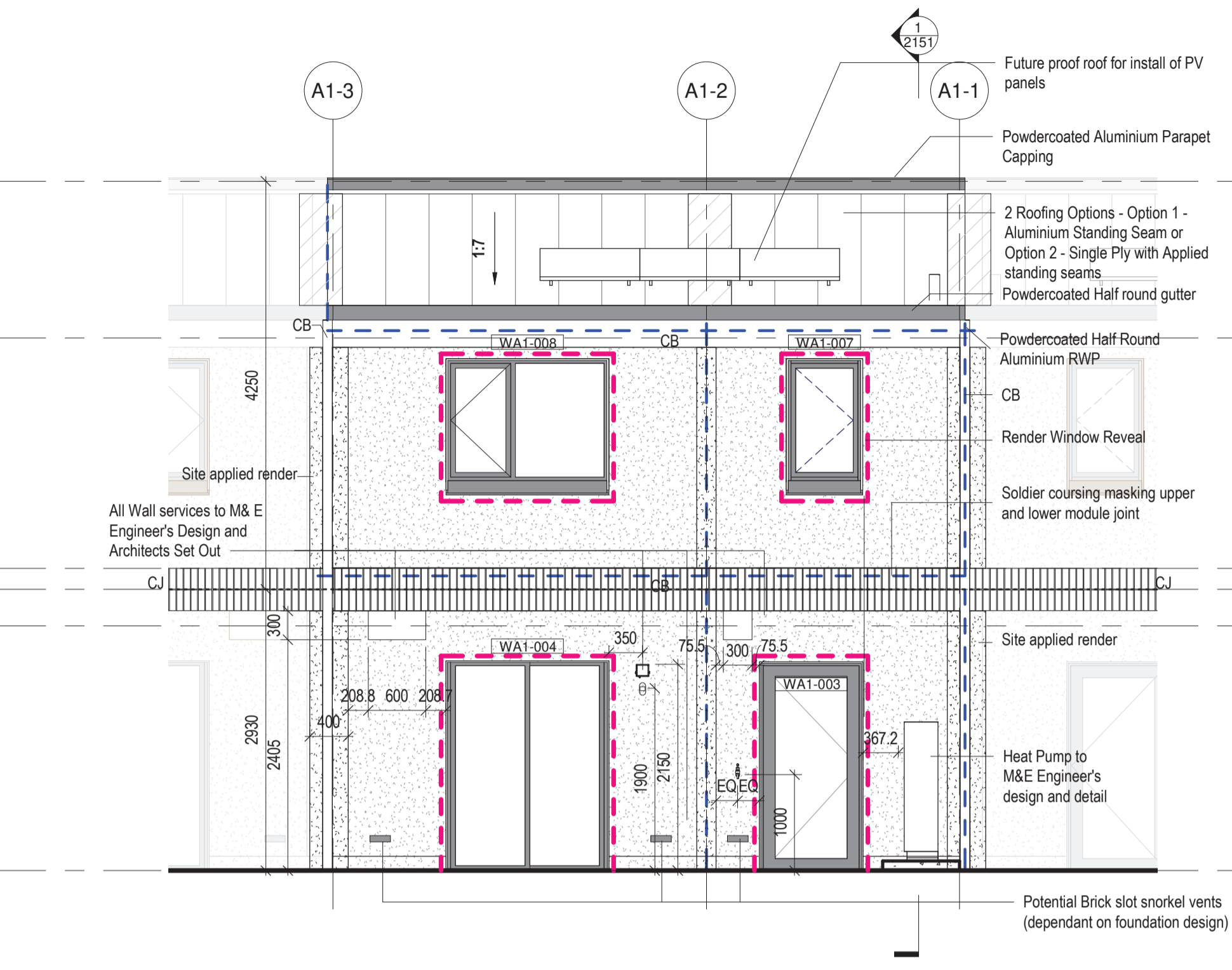

A1-R ELE-TYP-A1-REAR ELEVATION-MID TERRACE
1:50

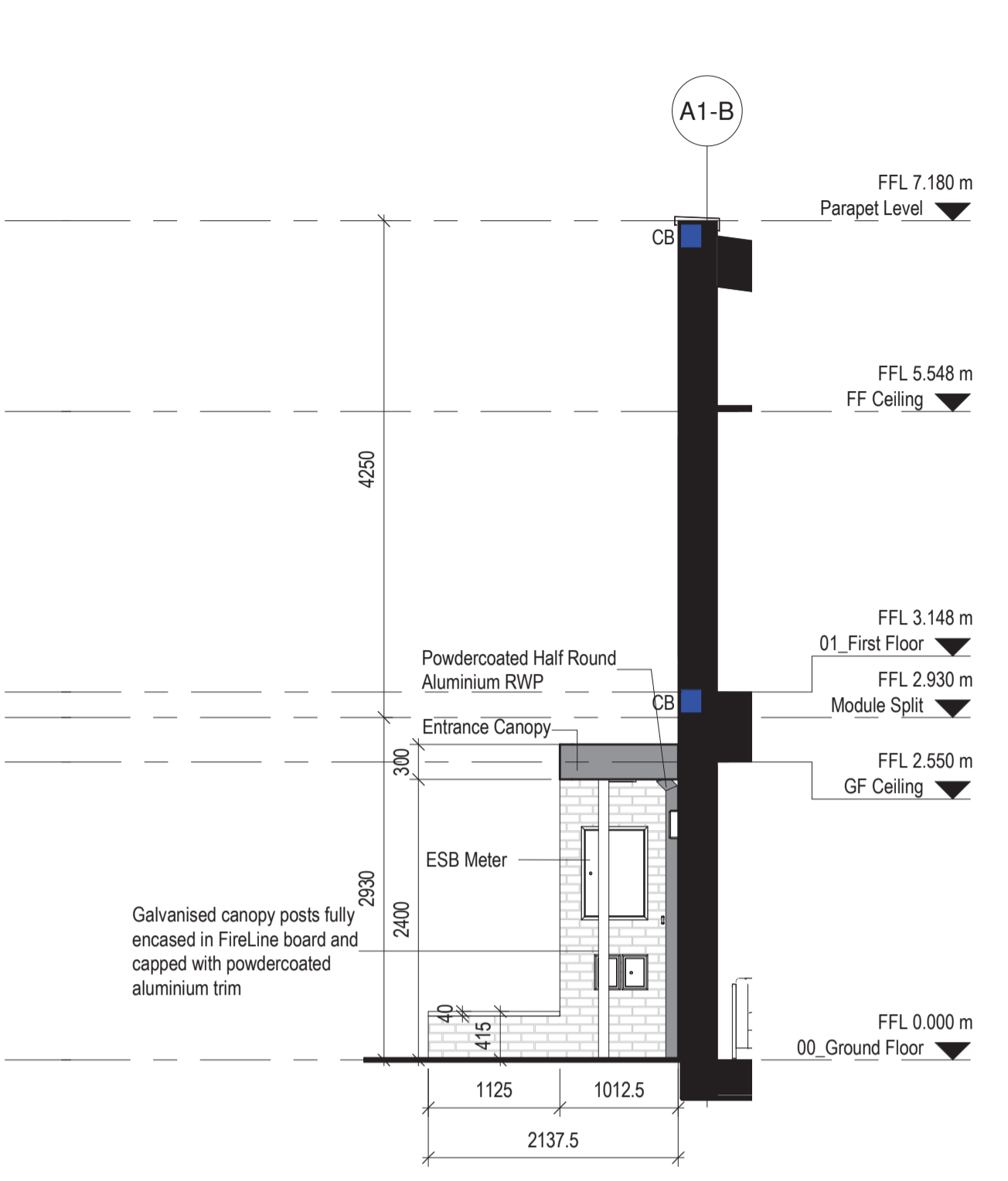

A1-S ELE-TYP-A1-SIDE ELEVATION-MID TERRACE
1:50

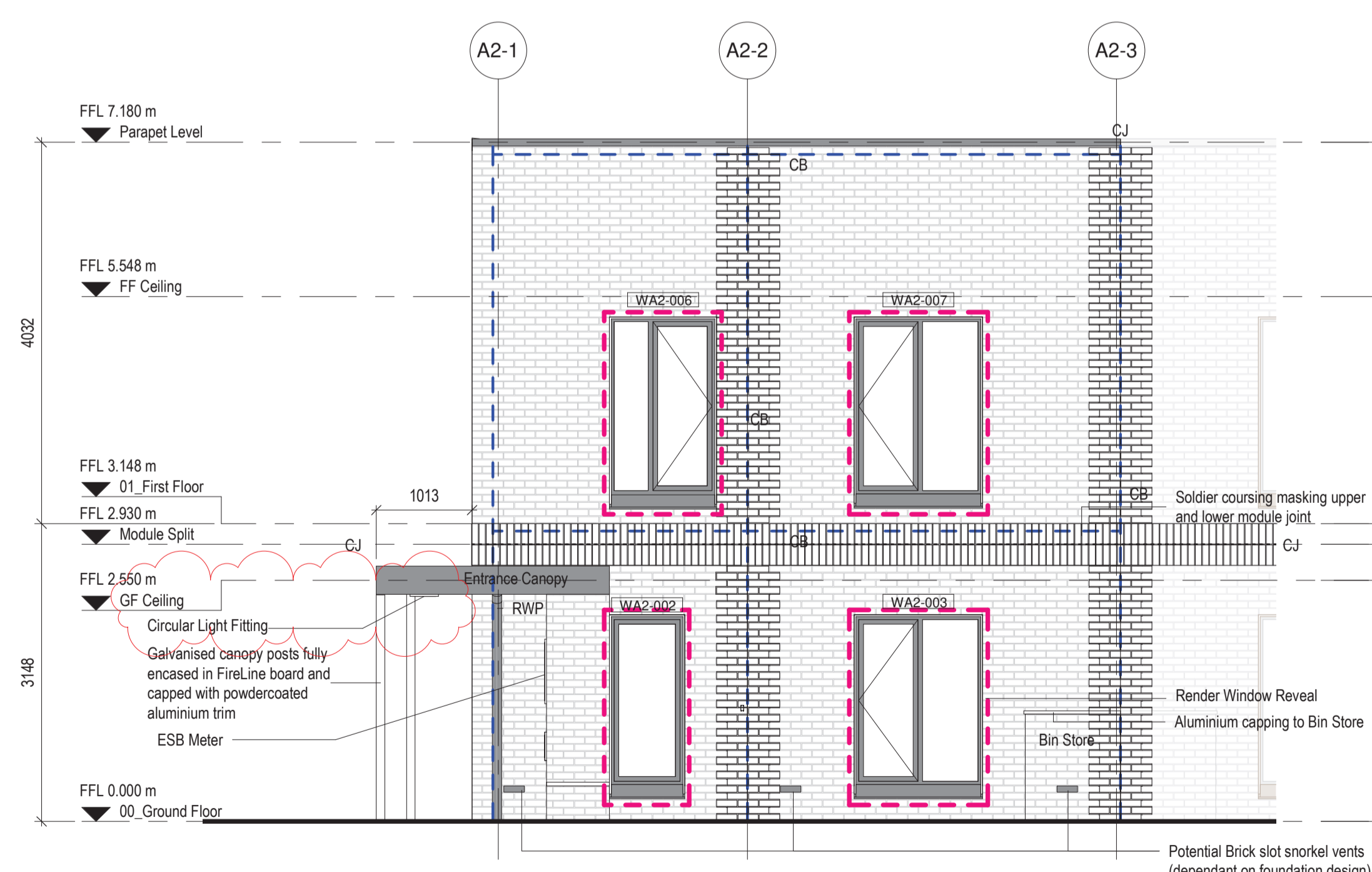

A2-F ELE-TYP-A2-FRONT ELEVATION-ACTIVE GABLE
1:50

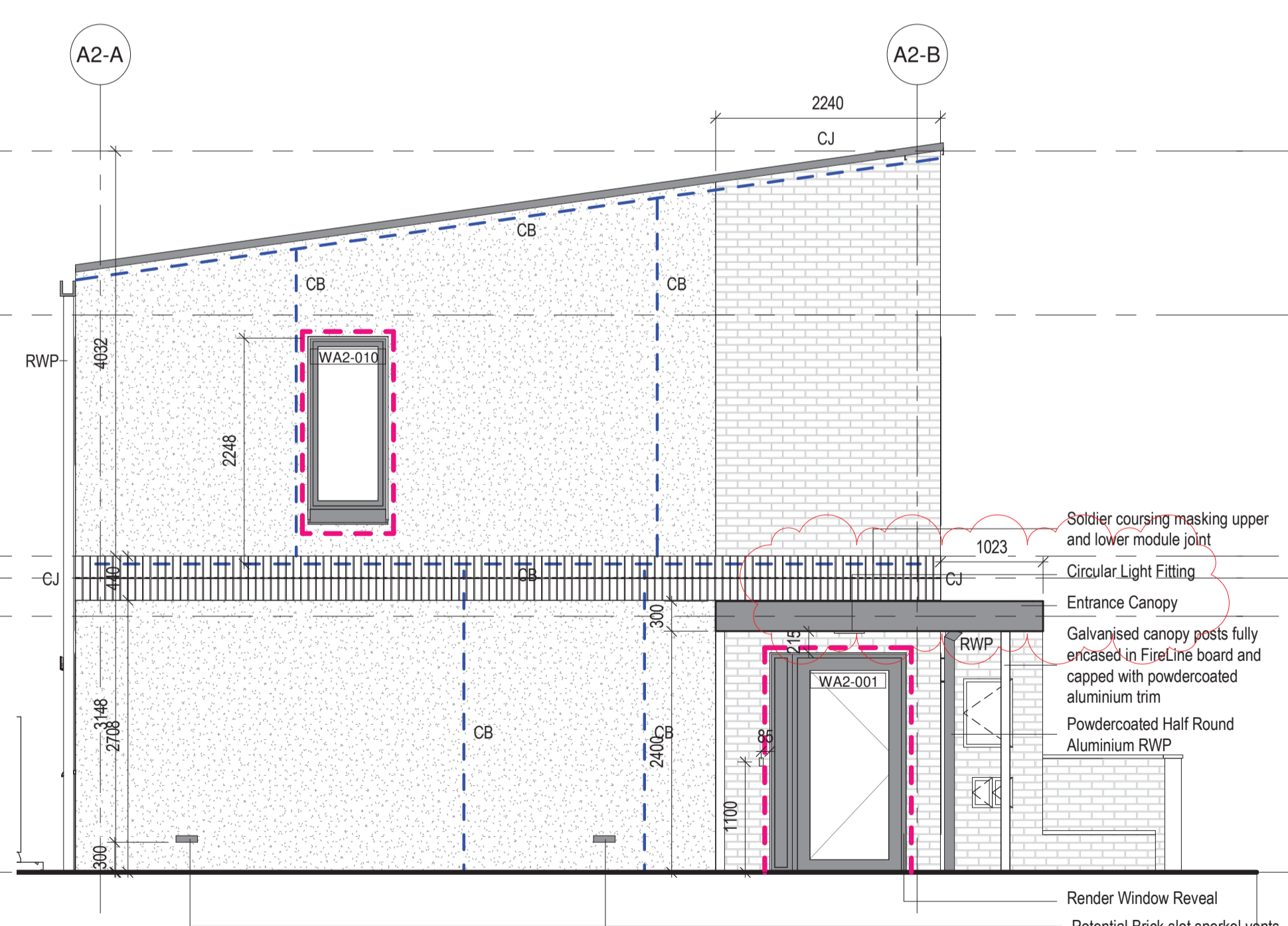

A2-S ELE-TYP-A2-SIDE ELEVATION-ACTIVE GABLE
1:50

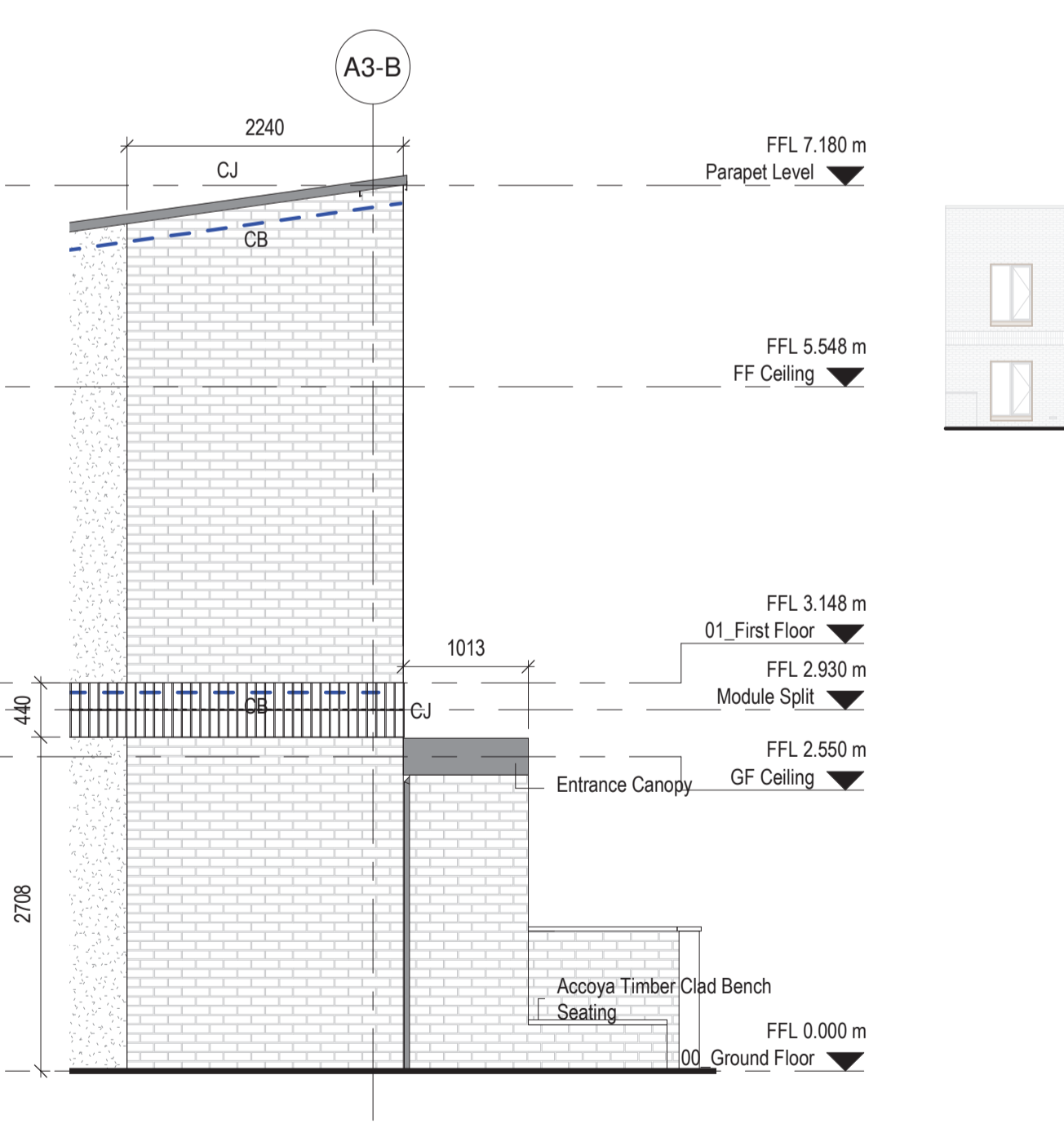

A3-S ELE-TYP-A3-SIDE ELEVATION-END TERRACE
1:50

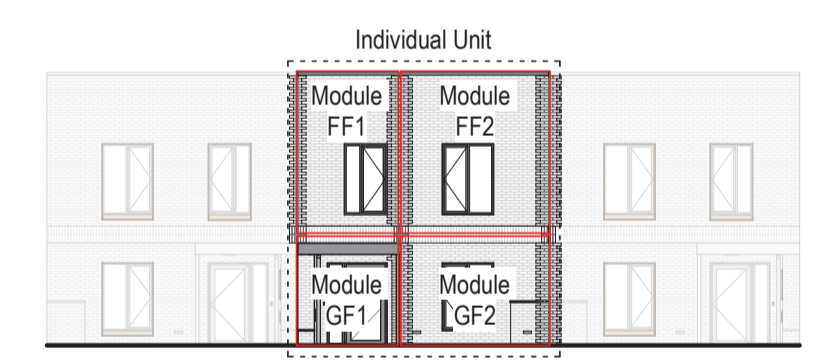

Revisions:

Rev	Description	Date	By
1	Issued for Information	14-04-2023	SC
2	Issued for Information	24-04-2023	SC
3	Issued for Tender	28-04-2023	SC
4	Issued for Tender	12-05-2023	SC
5	Issued for Tender	22-05-2023	SC
6	Issued for Tender	08-06-2023	SB
7	Issued for Tender	13-06-2023	SC

Project:
OPW Ukrainian Housing - Two Storey Modular Unit

Client:
SISK

Title:
GA Elevations - Type A

Drawing / Document Name:
2783JRMH-COA-00-ZZ-DR-A-2051

Suitability Status: Code - Description
D2 - For Tender

Revision:
P- 7

Scale @ A1 Drawn: Checked: Date:
 As indicated Sean Colley Steve Burke 14-04-2023

Notes:
 Do not scale from this drawing.
 Use figured dimensions only.
 All errors and omissions to be reported to the Architect.
 This drawing is to be read in conjunction with relevant consultant's drawings.
 All dimensions are in millimetres and all levels are in meters to match Datum unless otherwise noted.
 Contractor Design Responsibility
 It is noted that there are many elements within the works that require contractor design, and will be subject to certification as part of BCAR - see Preliminary Inspection Plan for clarity on certification required.
 © This drawing or design may not be reproduced without permission.

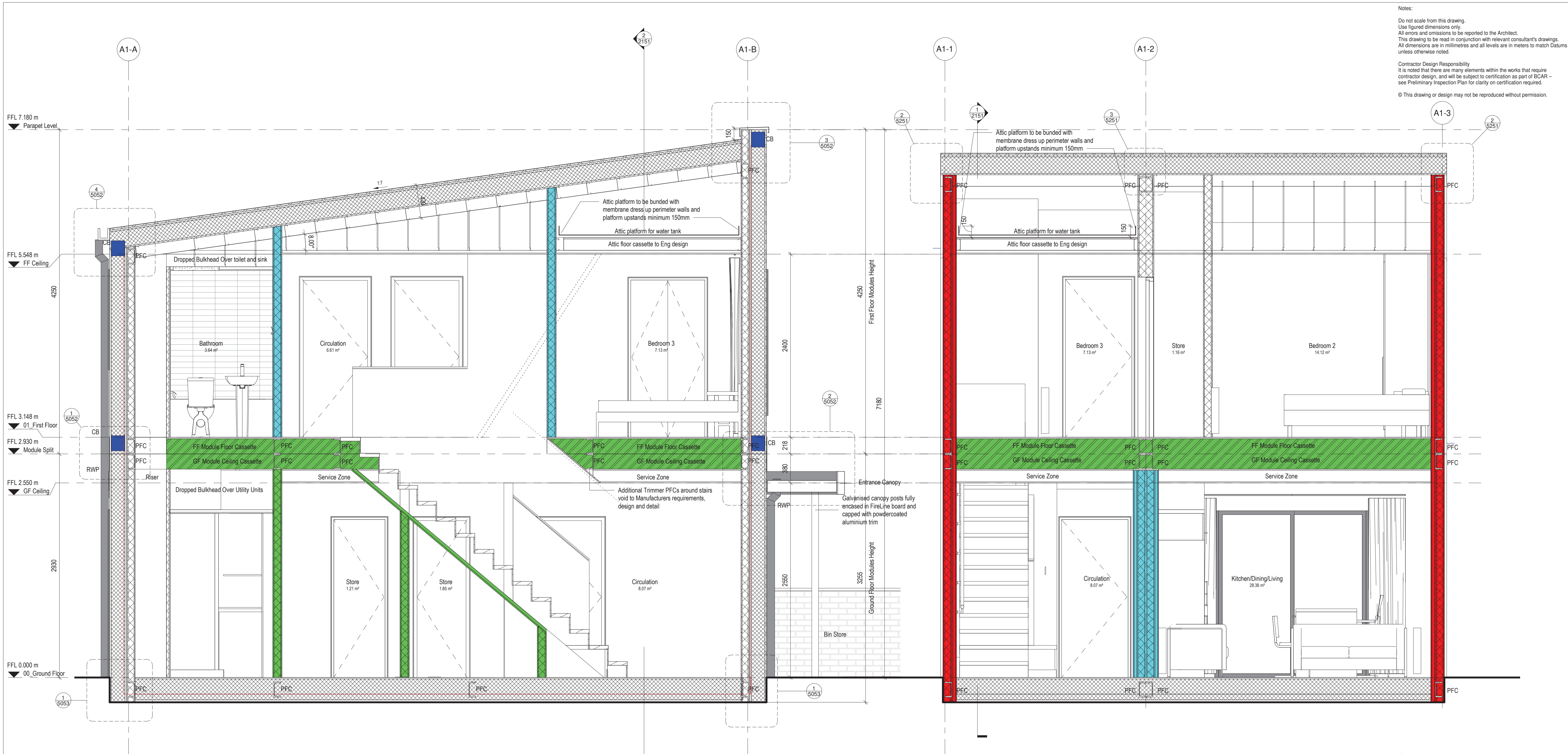

1 SEC-TYP-A1-SECTION 1-TYPICAL
1:25

2 SEC-TYP-A1-SECTION 2-TYPICAL
1:25

Legend

- Studwork
- CB Cavity barrier
- CC Cavity closer
- PFC Stainless Steel Paralled Flange Channel Section
- Control Joint
- Denotes 20 minute Fire Rated Construction
- Denotes 30 minute Fire Rated Construction
- Denotes 60 minute Fire Rated Construction

Note:
 Note: Refer to Civil / Structural Engineers Drawings for connection to main storm / surface water drainage system.
 Note: Refer to Mechanical / Electrical Engineers Drawings for connections to internal utilities & services systems.

Revisions:

Rev	Description	Date	By
1	Issued for Information	14-04-2023	SC
2	Issued as WIP	19-04-2023	SC
3	Issued for Information	24-04-2023	SC
4	Issued for Tender	28-04-2023	SC

Project:
OPW Ukrainian Housing - Two Storey Modular Unit

Client:
SISK

Title:
GA Sections - Type A

Drawing / Document Name:
2783JRMH-COA-00-ZZ-DR-A-2151

Suitability Status : Code - Description
D2 - For Tender Revision: **P- 4**

Scale @ A1 Drawn: Checked: Date:
 As indicated Steve Burke Steve Burke 14-04-2023

COADY
 ARCHITECTS

Mt Pleasant Business Ctr, Ranelagh, Dublin 6, D06 X7P8
 Unit 8A Oram Point, Main St, Crammore, Co. Galway
 01 497 6786 | 091 788 325 | admin@coady.ie | www.coady.ie

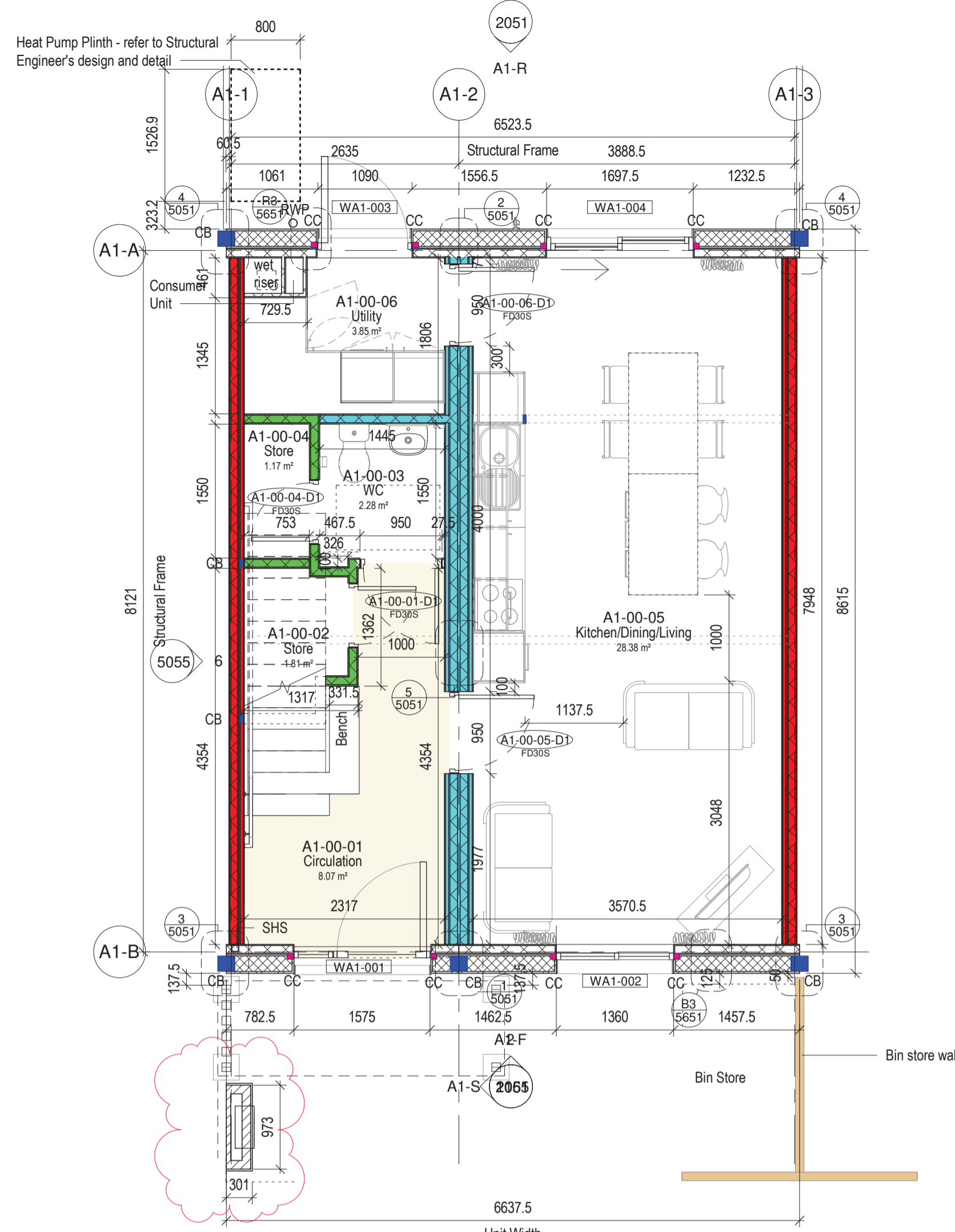

A1-0 GA-TYP-A1-00-Ground-Floor-Plan TYPICAL/MID TERRACE
1:50

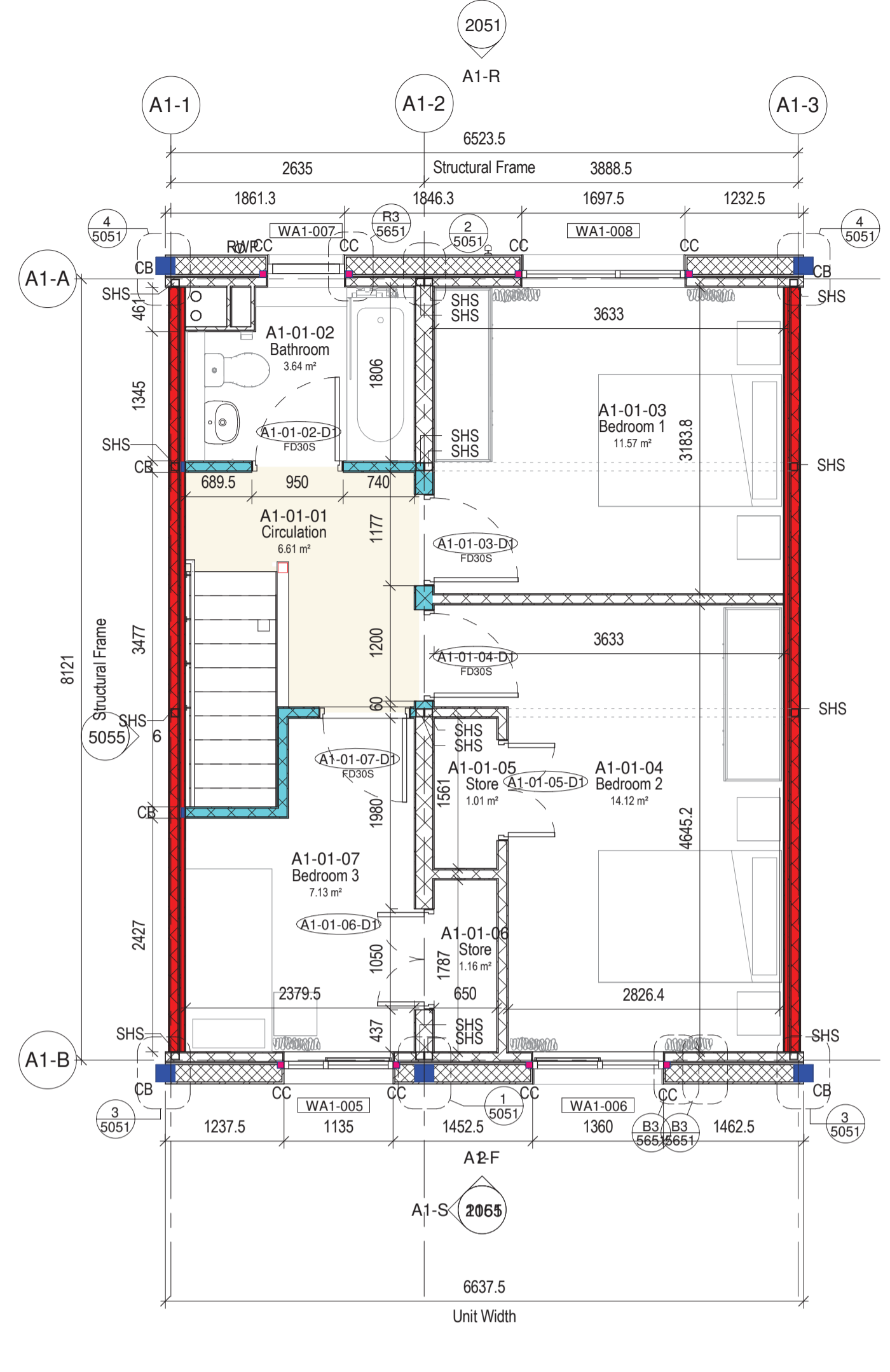

A1-1 GA-TYP-A1-01-First-Floor-Plan TYPICAL/MID TERRACE
1:50

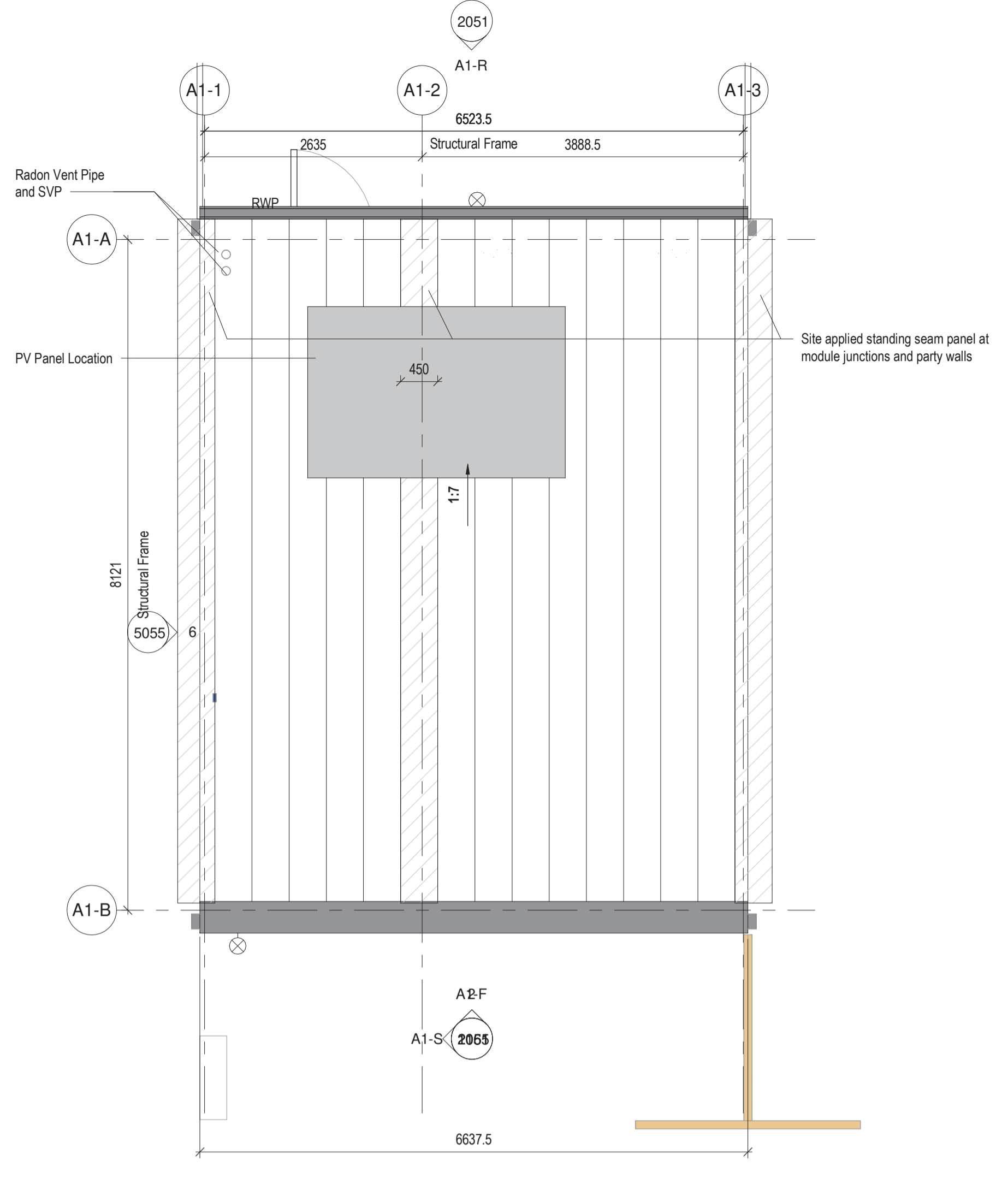

A1-2 GA-TYP-A1-02-Roof-Floor-Plan TYPICAL/MID TERRACE
1:50

Notes:
Do not scale from this drawing.
Use figured dimensions only.
All areas and omissions to be reported to the Architect.
This drawing is to be read in conjunction with relevant consultant's drawings.
All dimensions are in millimetres and all levels are in meters to match Datums unless otherwise noted.

Contractor Design Responsibility
It is noted that there are many elements within the works that require contractor design, and will be subject to certification as part of BCAR - see Preliminary Inspection Plan for clarity on certification required.

© This drawing or design may not be reproduced without permission.

- Legend**
- Studwork
 - Door reference tag
 - Window / Rooflight reference tag
 - CB
 - CC
 - SHS
 - Control Joint
 - Denotes 20 minute Fire Rated Construction
 - Denotes 30 minute Fire Rated Construction
 - Denotes 60 minute Fire Rated Construction
- Note:
Note: Refer to Civil / Structural Engineers Drawings for connection to main storm / surface water drainage system.
Note: Refer to Mechanical / Electrical Engineers Drawings for connections to internal utilities & services systems.

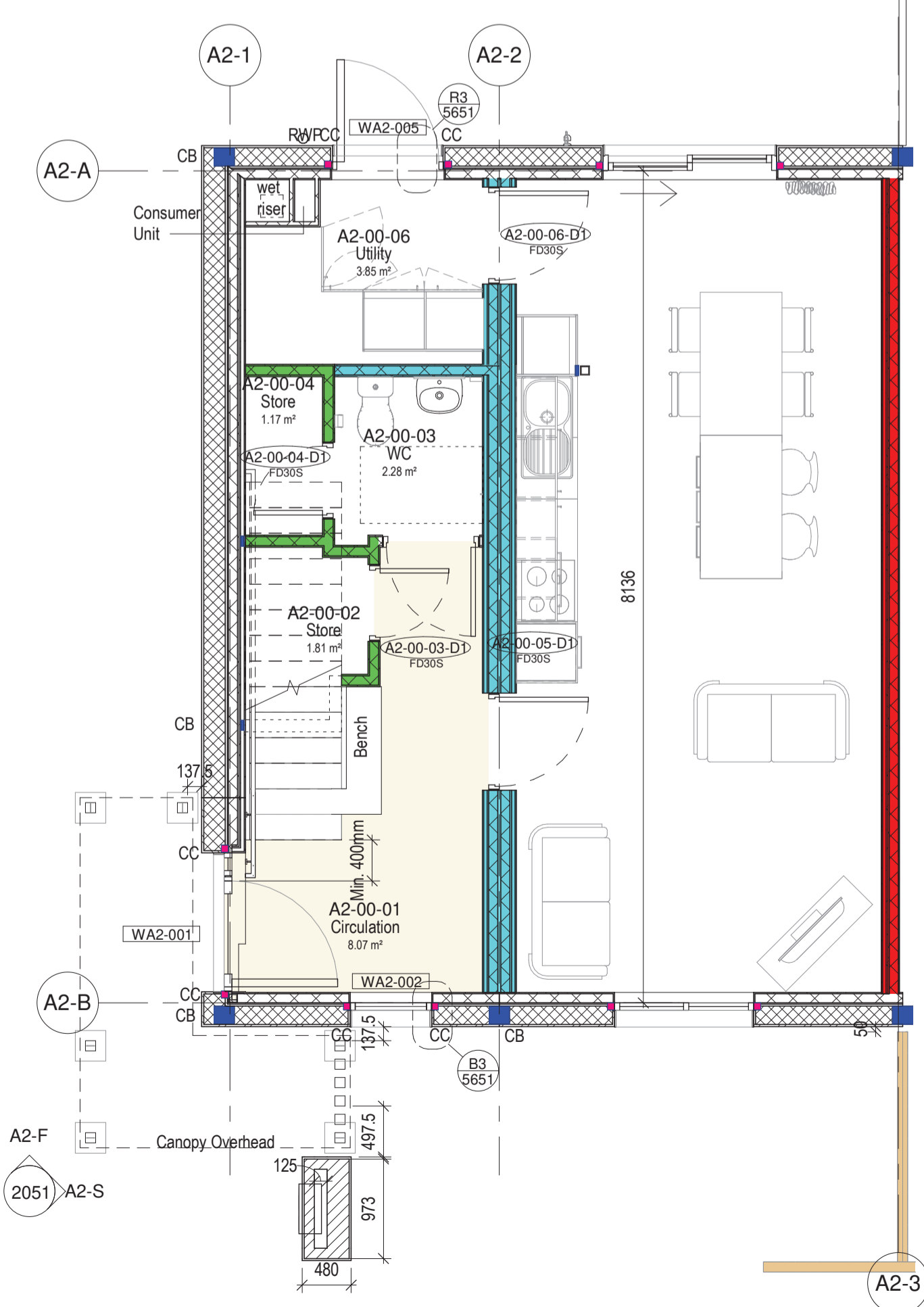

A2-0 GA-TYP-A2-00-Ground-Floor-Plan ACTIVE GABLE
1:50

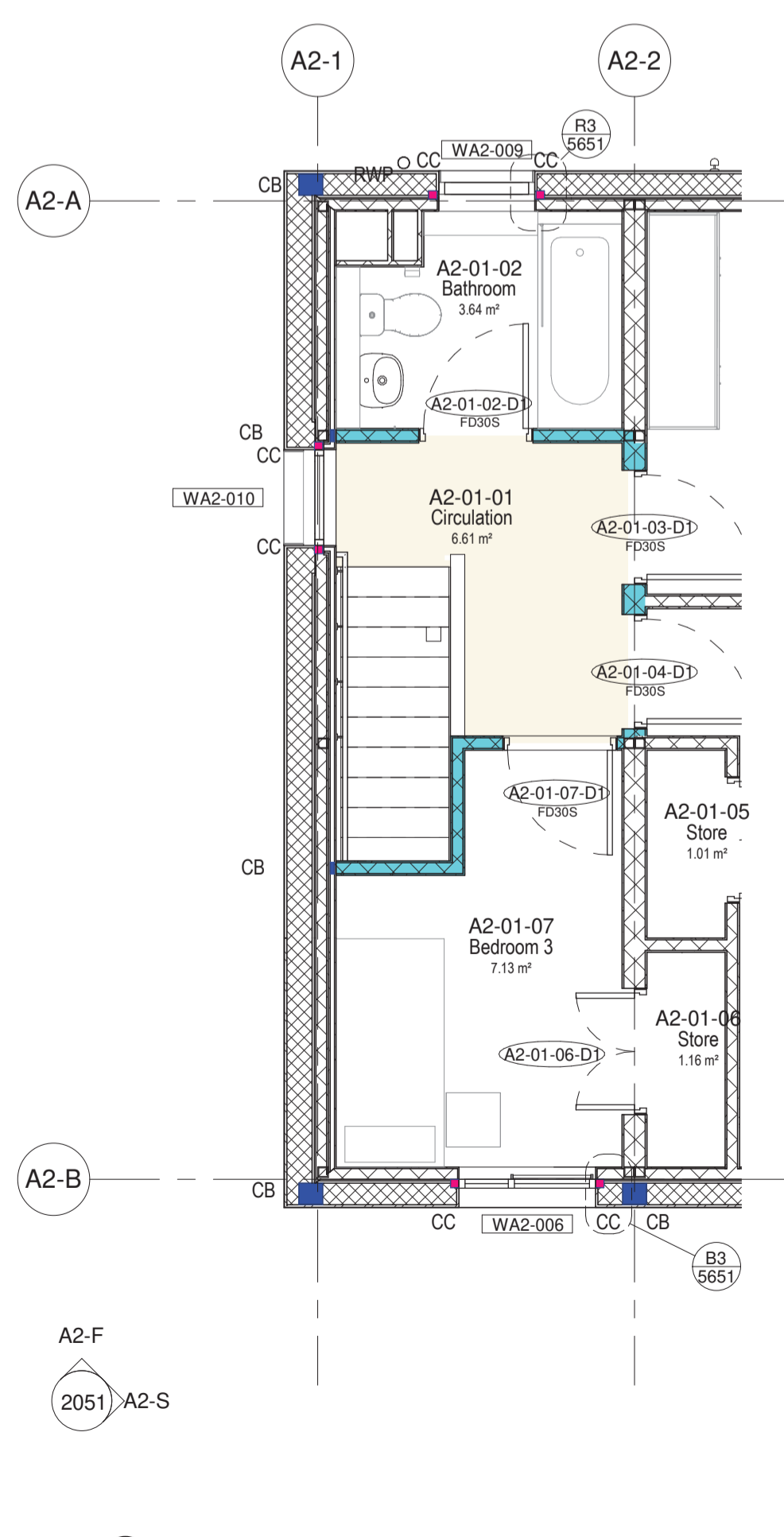

A2-1 GA-TYP-A2-01-First-Floor-Plan ACTIVE GABLE
1:50

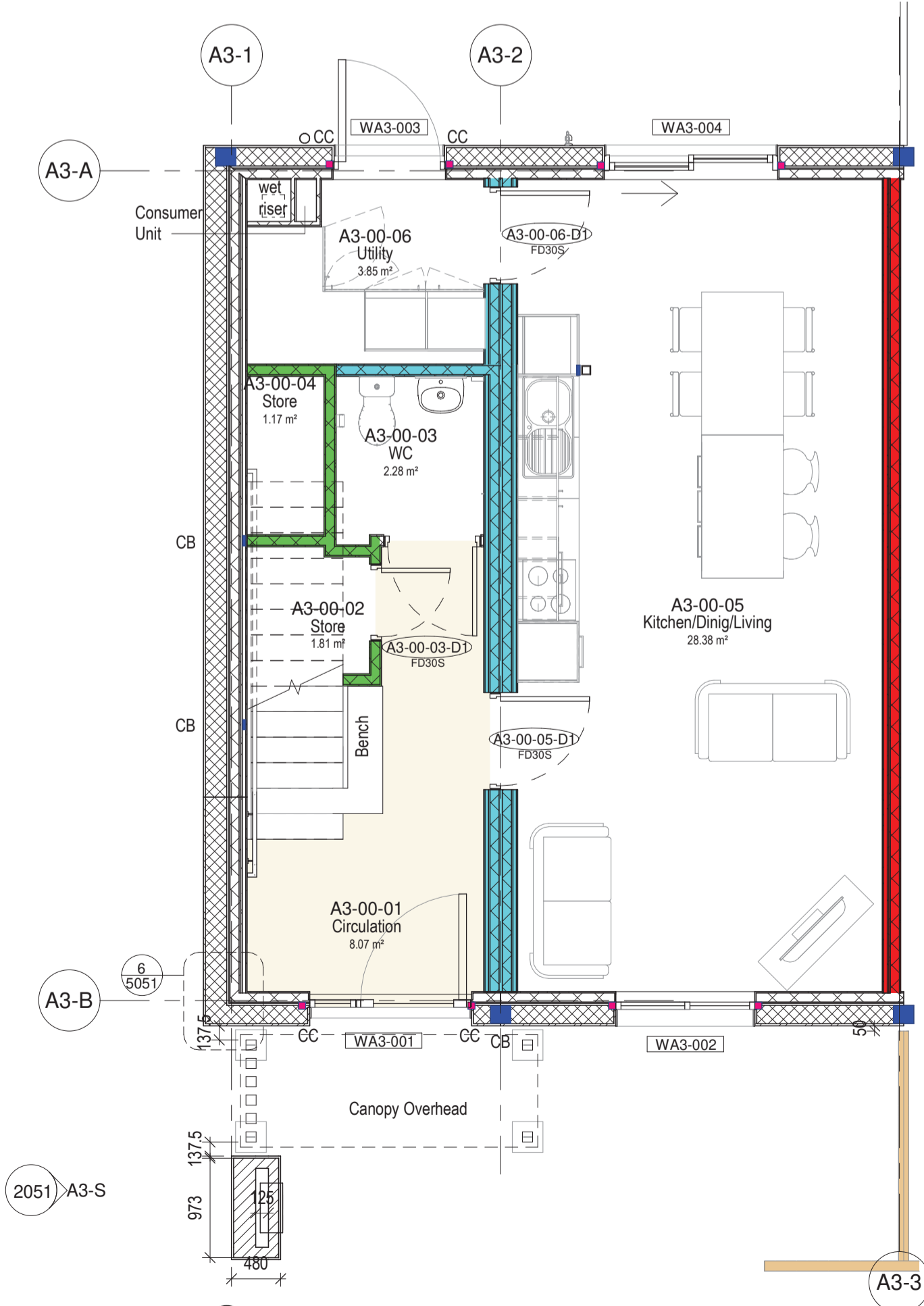

A3-0 GA-TYP-A3-00-Ground-Floor-Plan END TERRACE
1:50

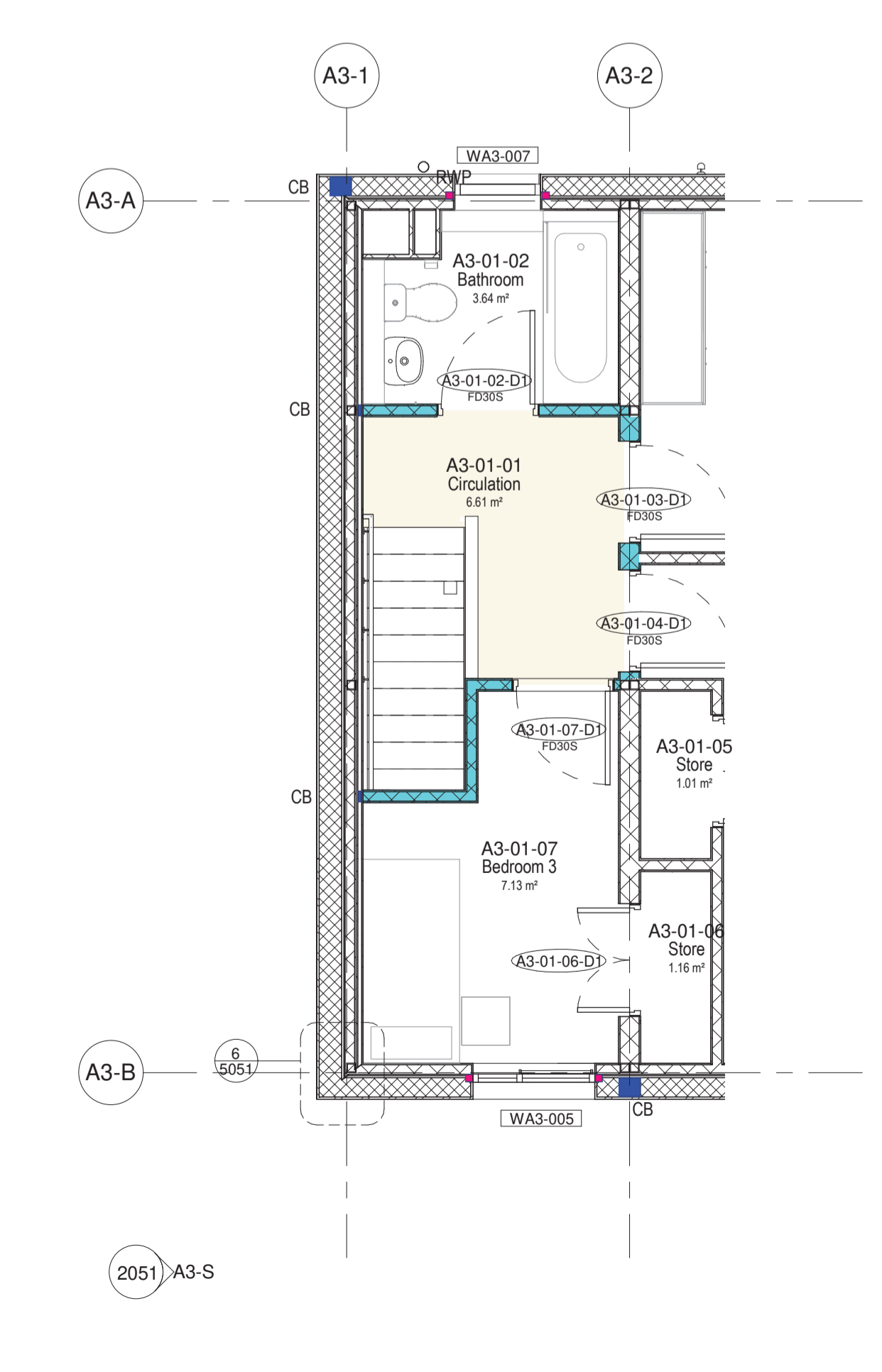

A3-1 GA-TYP-A3-01-First-Floor-Plan END TERRACE
1:50

Revisions:

Rev	Description	Date	By
4	Issued for Tender	12-04-2023	SC
5	Issued for Tender	12-05-2023	SC
6	Issued for Tender	22-05-2023	SC
7	Issued for Tender	08-06-2023	SB
8	Issued for Construction	02-11-2023	SC
9	Issued for Construction	24-11-2023	SC
10	Issued for Construction	28-11-2023	SC
11	Issued for Construction	30-11-2023	SB
12	Issued for Construction	03-01-2024	SC
13	Issued for Construction	04-01-2024	SC

Project:
OPW Ukrainian Housing - Two Storey Modular Unit

Client:
SISK

Title:
GA Plans - Type A

Drawing / Document Name:
2783 URMH2-COA-00-ZZ-DR-A-1151

Suitability Status : Code - Description
A4 - For Construction C-13

Scale @ A1 Drawn: Checked: Date:
As indicated Sean Colley Steve Burke 14-04-2023







COADY
ARCHITECTS
Mt Pleasant Business Ctr, Ranelagh, Dublin 6, D06 X7P8
Unit 8A Cran Point, Main St, Crammore, Co. Galway
01 491 6786 | 091 788 325 | admin@coady.ie | www.coady.ie

Notes:
 Do not scale from this drawing.
 Use figured dimensions only.
 All errors and omissions to be reported to the Architect.
 This drawing to be read in conjunction with relevant consultant's drawings.
 All dimensions are in millimetres and all levels are in meters to match Datum unless otherwise noted.

Contractor Design Responsibility
 It is noted that there are many elements within the works that require contractor design, and will be subject to certification as part of BCAR - see Preliminary Inspection Plan for clarity on certification required.

© This drawing or design may not be reproduced without permission.

Legend

-  Control Joint
-  Set Out Centre Point
-  Direction of module panel expansion & tolerance zone
-  Cavity Barriers
-  Radon Vent Cap
-  Rain Water Pipe

Note:
 Set Out Centre Point is from centre of all unit modules i.e. between ground and first floor and LHS and RHS junction. Rational that expansion and tolerances between modules will be dealt with at control joints between units, below plinth level and within parapet capping, therefore being masked. Front face of units to be flush and aligned, with any expansion and/or tolerance dealt with at rear elevation.

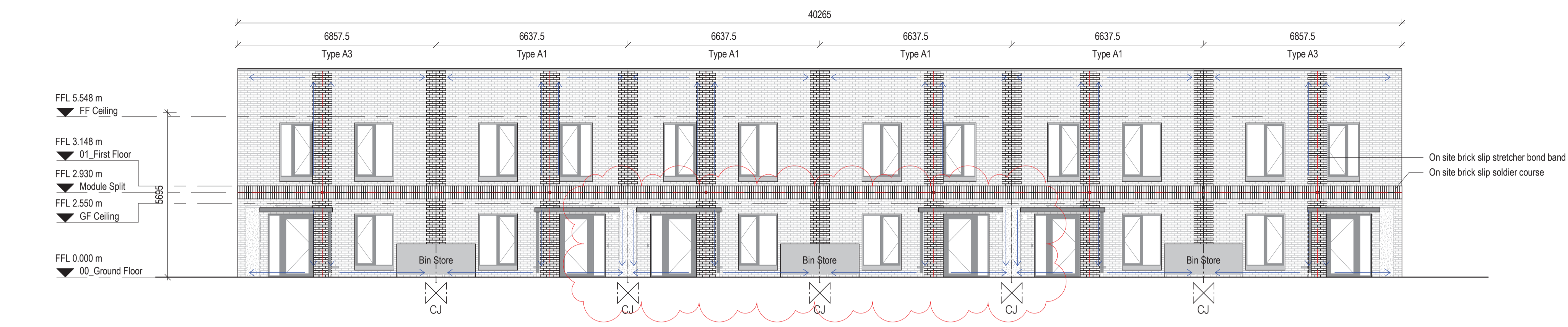

1 Block 2 - Elevation - Front
1:100

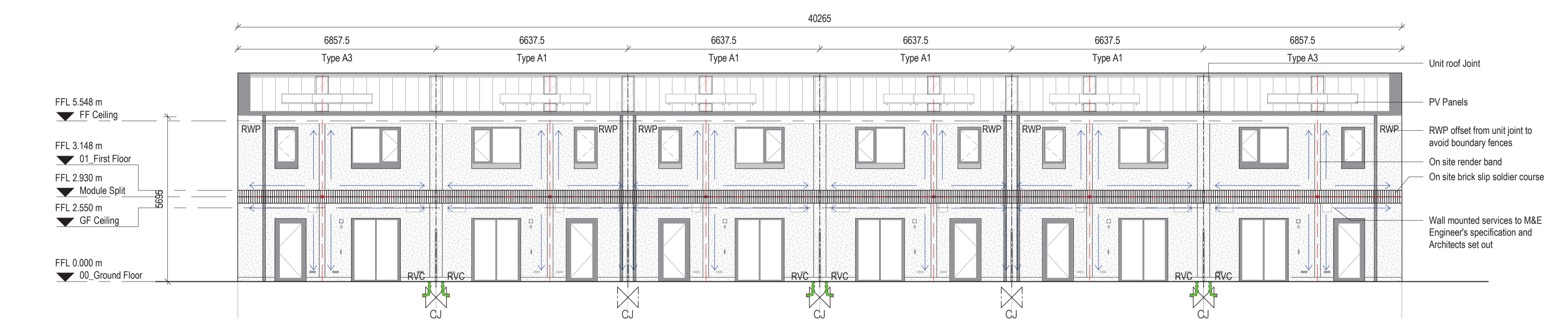

2 Block 2 - Elevation - Rear
1:100

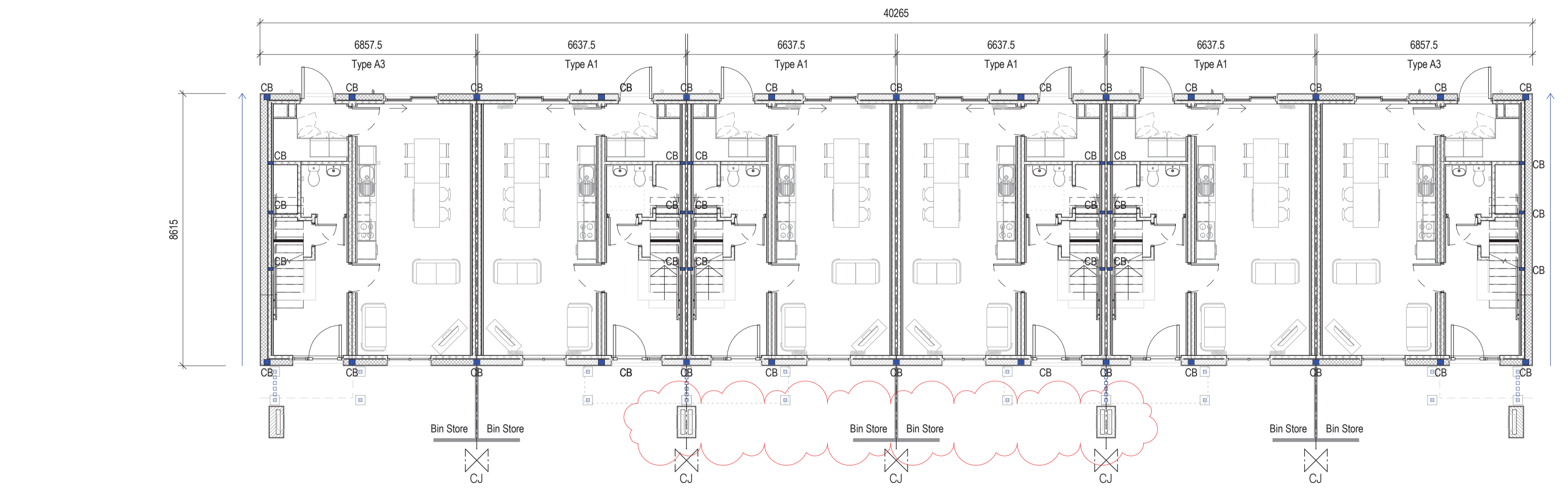

3 BLOCK 2-Plan
1:100

Revisions:

Rev	Description	Date	By
1	Issued for Tender	28-04-2023	SC
2	Issued for Tender	12-05-2023	SC
3	Issued for Tender	22-05-2023	SC
4	Issued for Tender	08-06-2023	SB
5	Issued for Tender	13-06-2022	SC
6	Issued for Construction	07-12-2023	SC
7	Issued for Construction	03-01-2024	SC
8	Issued for Construction	04-01-2024	SC

Project:
OPW Ukrainian Housing - Two Storey Modular Unit

Client:
SISK

Title:
Block Plans - Block 2

Drawing / Document Name:
 Project Number Project Originator Volume Level Type Rate Sheet Number
2783 URMH2-COA-00-ZZ-DR-A-1153

Suitability Status : Code - Description Revision:
A4 - For Construction C- 8

Scale @ A1 Drawn: Checked: Date:
 1 : 100 Sean Colley Steve Burke 28-04-2023

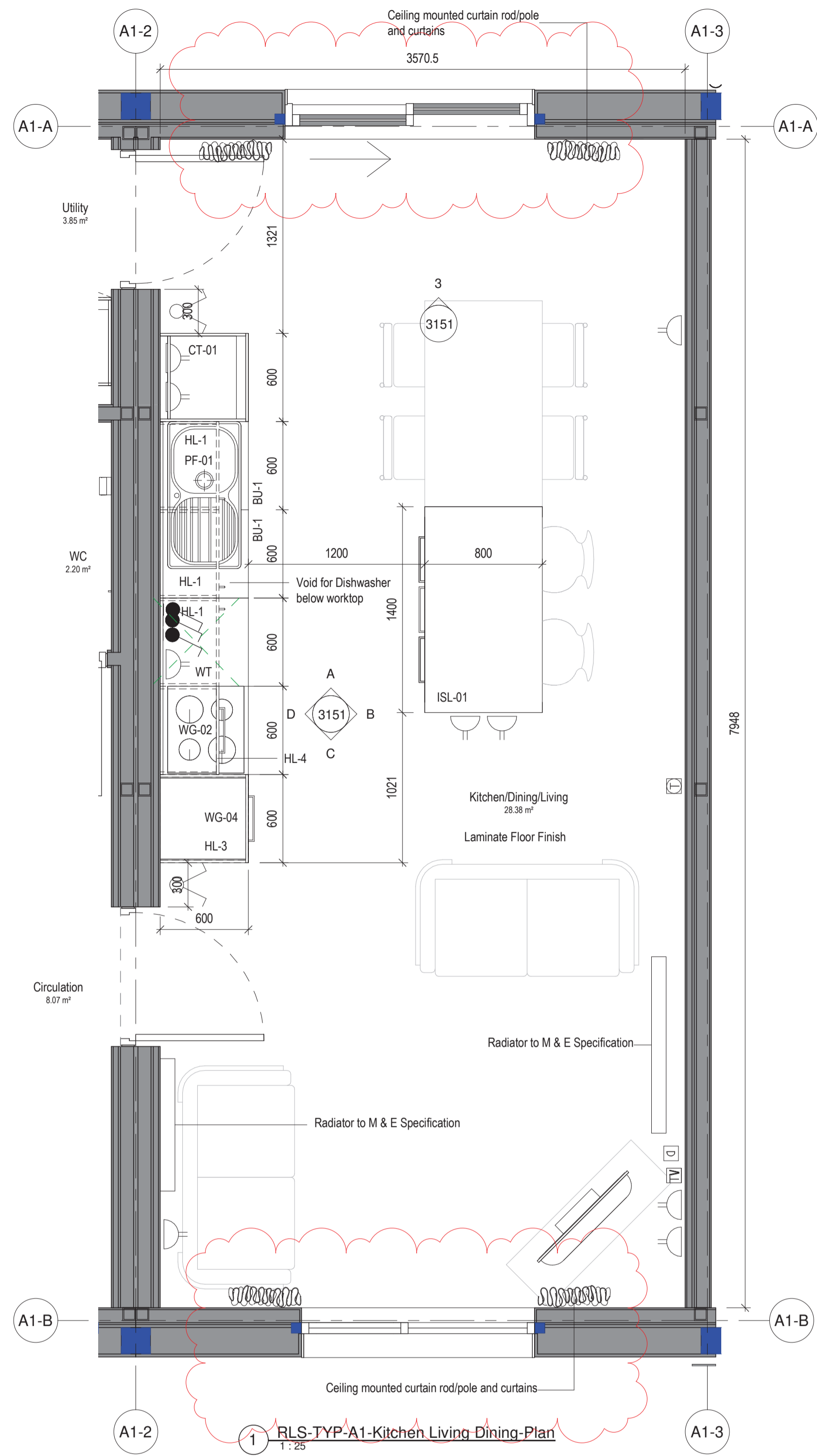

1 RLS-TYP-A1-Kitchen Living Dining-Plan
1:25

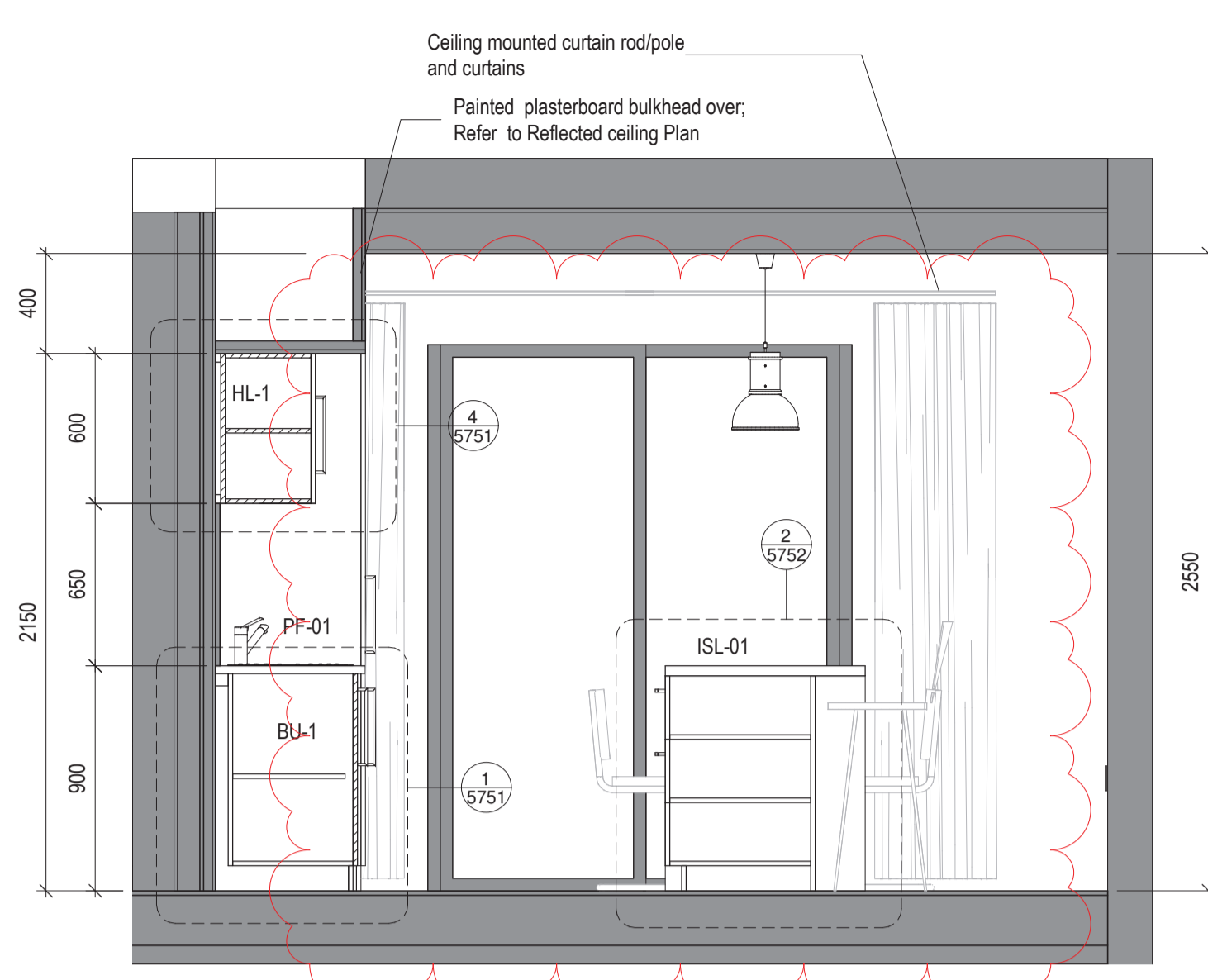

A RLS-TYP-A1-Kitchen Living Dining - ELEV A
1:25

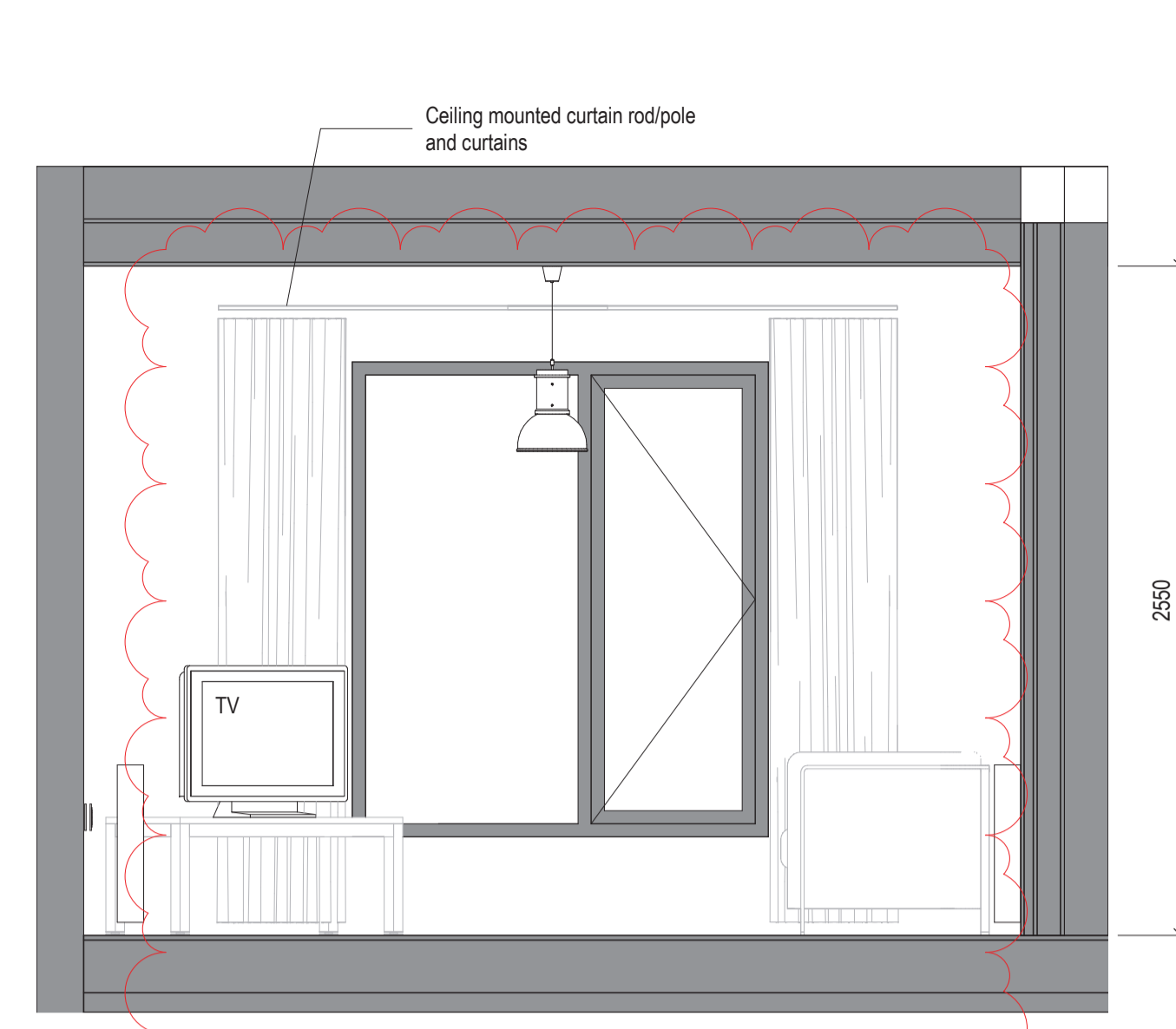

C RLS-TYP-A1-Kitchen Living Dining - ELEV C
1:25

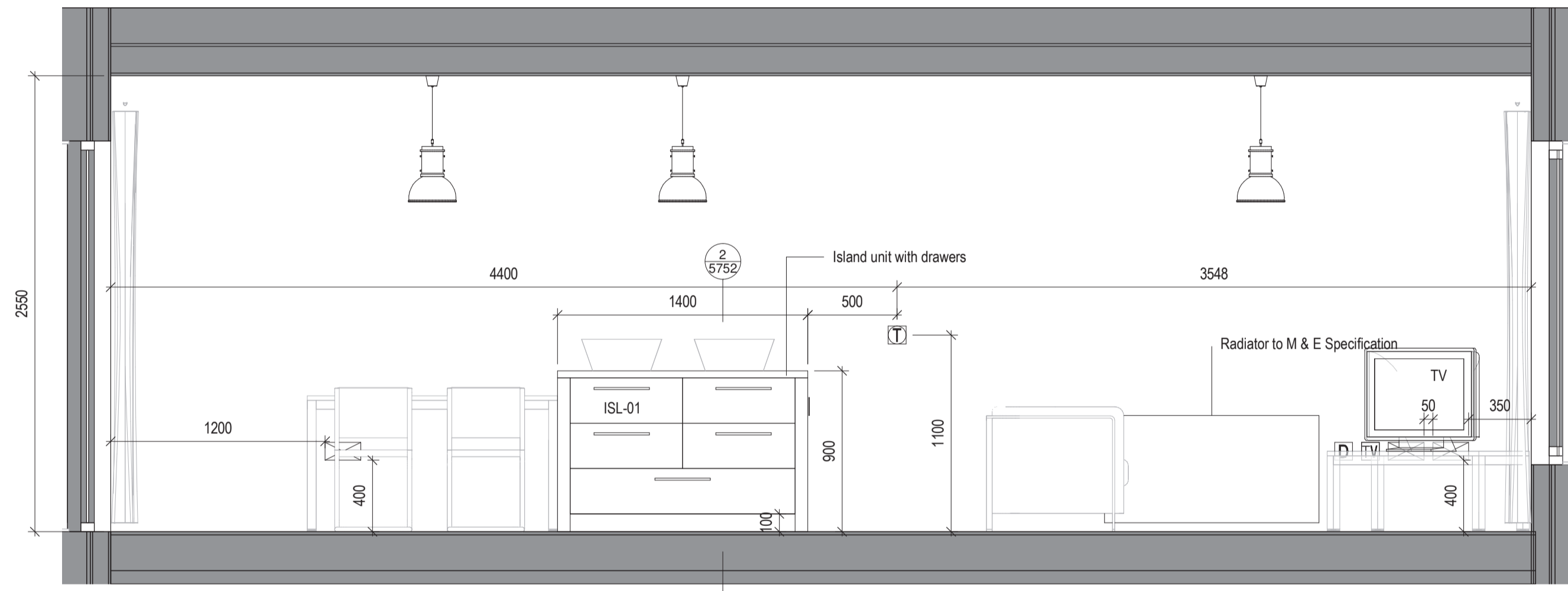

B RLS-TYP-A1-Kitchen Living Dining - ELEV B
1:25

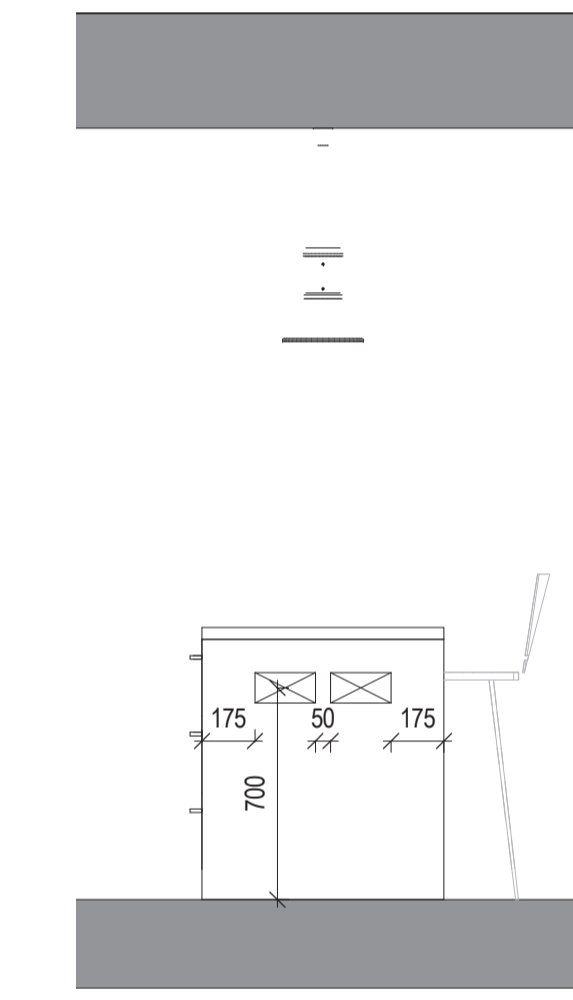

3 RLS-TYP-A1-Kitchen Living Dining - ELEV E
1:25

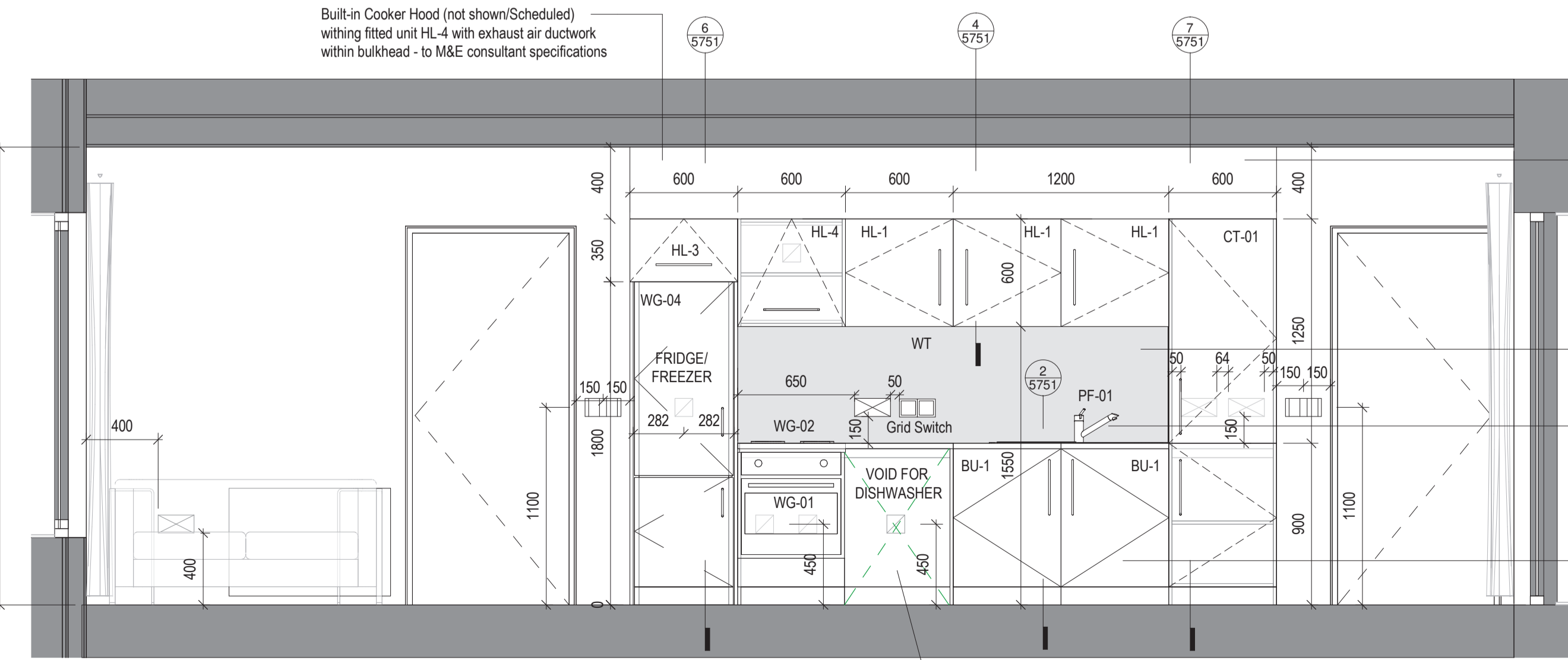

D RLS-TYP-A1-Kitchen Living Dining - ELEV D
1:25

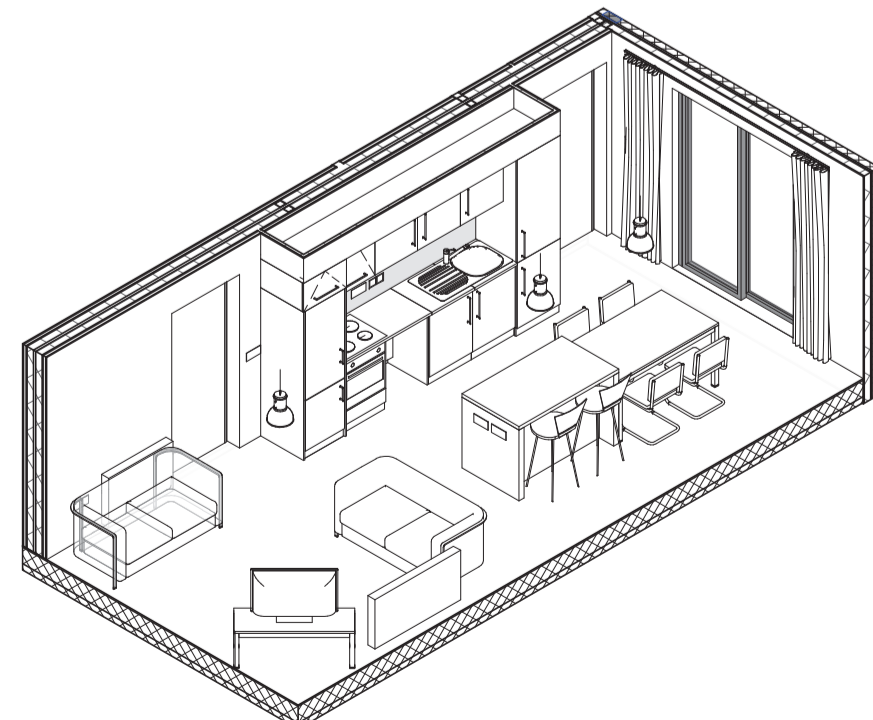

2 RLS-TYP-A1-Kitchen Living Dining-3D
1:25

Ref.	Description	Qty:
BU-1	Base unit - 600mm D x 900mm high - length as required	2
CT-01	Tall Storage Unit - 600mm D x 215mm H consisting of High and Low Level storage with adjustable shelves and doors	1
HL-1	High level storage cabinets - 600Wx400Dx600H - Side Hung	3
HL-3	High level press - 600Wx600Dx350H - Top Hung; with gable ends below either side of fridge/freezer void	1
HL-4	High level press - 600Wx400Dx600H - Top hung for Extractor Fan	1
ISL-01	Island Unit - 800x1400mm x 900mm H - comprising drawers	1
WT	Worktop - 600mm D x 900mm H	1

Notes:

Do not scale from this drawing.
Use figured dimensions only.
All errors and omissions to be reported to the Architect.
This drawing to be read in conjunction with relevant consultant's drawings.
All dimensions are in millimetres and all levels are in millimetres to match Datum unless otherwise noted.

Contractor Design Responsibility
It is noted that there are many elements within the works that require contractor design, and will be subject to certification as part of BCAR - see Preliminary Inspection Plan for clarity on certification required.

© This drawing or design may not be reproduced without permission.

Legend:

	Plan	Elevation
Light Switch		
Single Switched Socket Outlet		
Twin Switched Socket Outlet		
Telephone Point		
Cleaners Socket Outlet		
Public Speakers Address		
Dado Trunking		
Network Point		
Sub Distribution Board (Possible Location)		
Single Phase Isolator		
Three Phase Isolator		
Electric Emergency Knockout Point		
Key Operating Isolating Switch-ICT Installation Only		
Key Operating Isolator / Knockout Button-Elec. Supply		
Gas Pressure Proving System (With Key Switch)		
Gas Emergency Knockout Point		
Projector Audio Faceplate		
Data Projector Isolator Switch		
Thermostat Control		
Isolation Switch		
Gas Alarm Slam Shut		
Fire Alarm Break Glass		
Cooker Point 45A		
Exit Sign - Positioned 2.4m AFFL		
PA Console		
Security Alarm Panel / Panic Button		
Fire Alarm Panel		
Mechanical Ventilation Power Point		

NOTE:
Loose furniture shown as indicative only;
All loose furniture to be procured by Client.

Revisions:

Rev	Description	Date	By
1	Issued for Tender	28-04-2023	SC
2	Issued for Tender	08-05-2023	SC
3	Issued for Tender	12-05-2023	SC

Project:
OPW Ukrainian Housing - Two Storey Modular Unit

Client:
SISK

Title:
RLS_Type A1_Kitchen Living Dining

Drawing / Document Name:
Project Number: **2783JRMH-COA-00-ZZ-DR-A-3151**

Suitability Status: Code - Description
D2 - For Tender

Revision:
P-3

Scale @ A1 Drawn: Lee-Ann Ford Checked: Steve Burke Date: 25-04-2023

COADY
ARCHITECTS

Mt Pleasant Business Ctr, Ranelagh, Dublin 6, D06 X7P8
Unit 8A Cran Point, Main St, Crummore, Co. Galway
01 407 6786 | 091 788 325 | admin@coady.ie | www.coady.ie

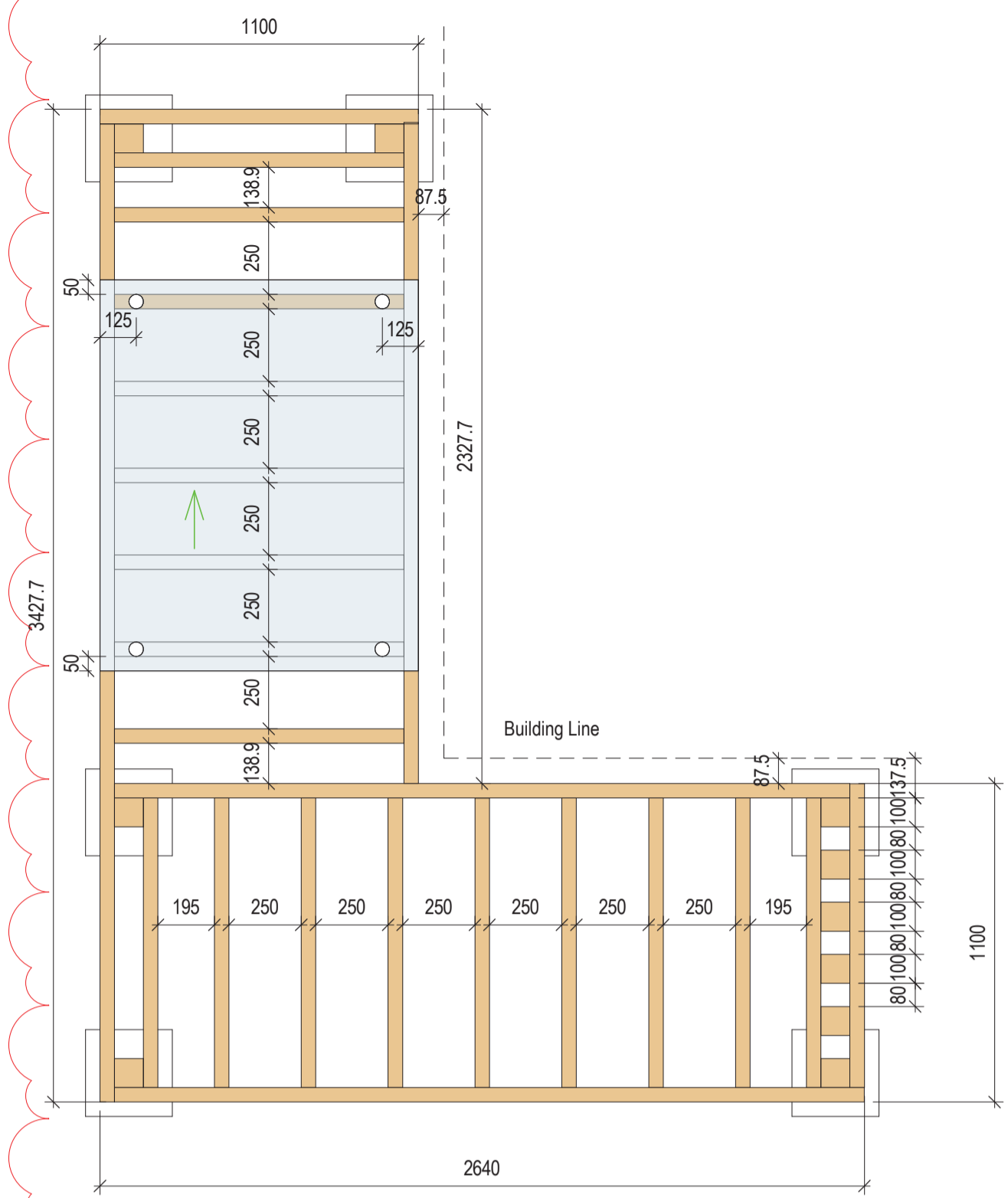

8 A2 Canopy-Roof Plan
1:25

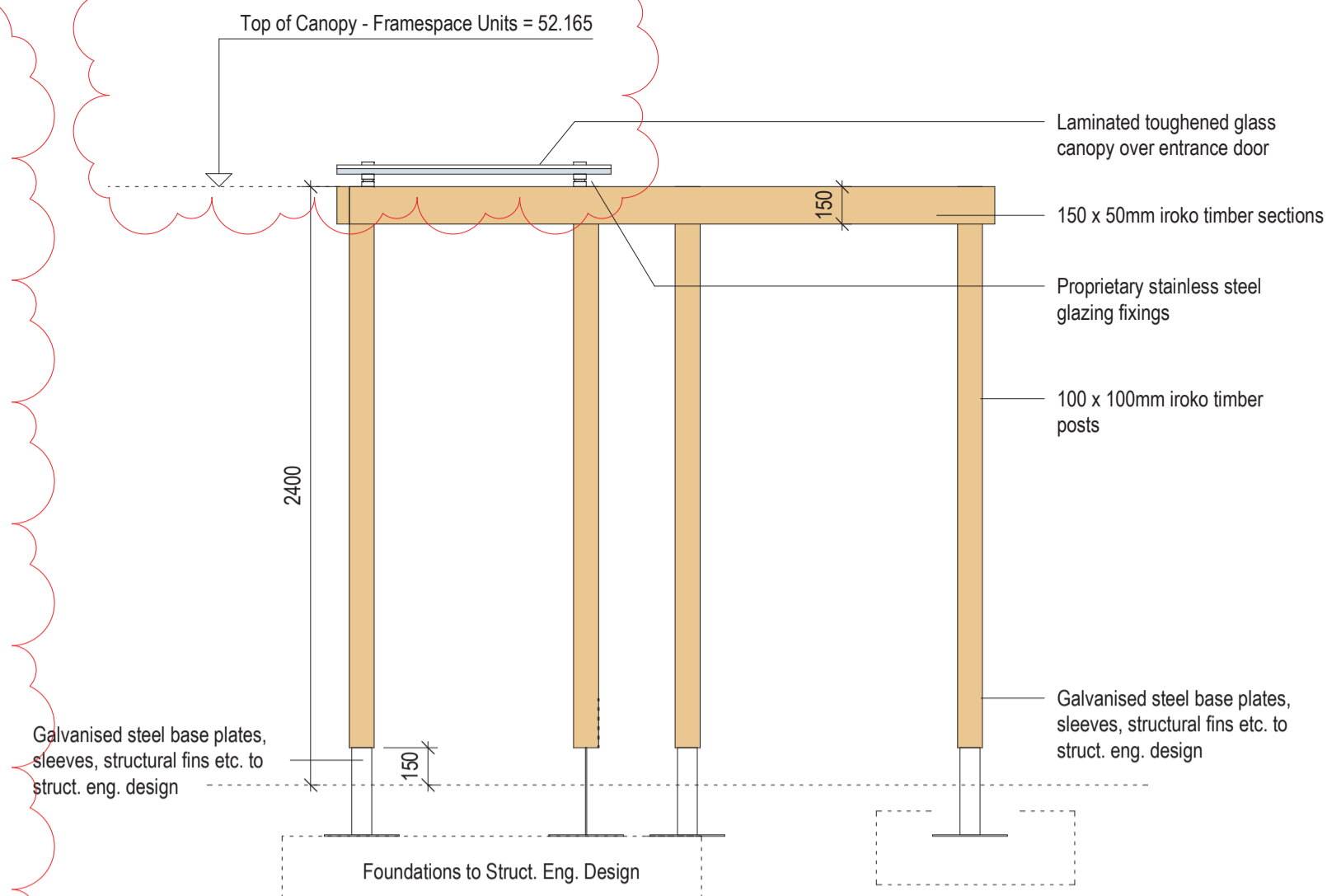

9 A2 Canopy - Elevation 1
1:25

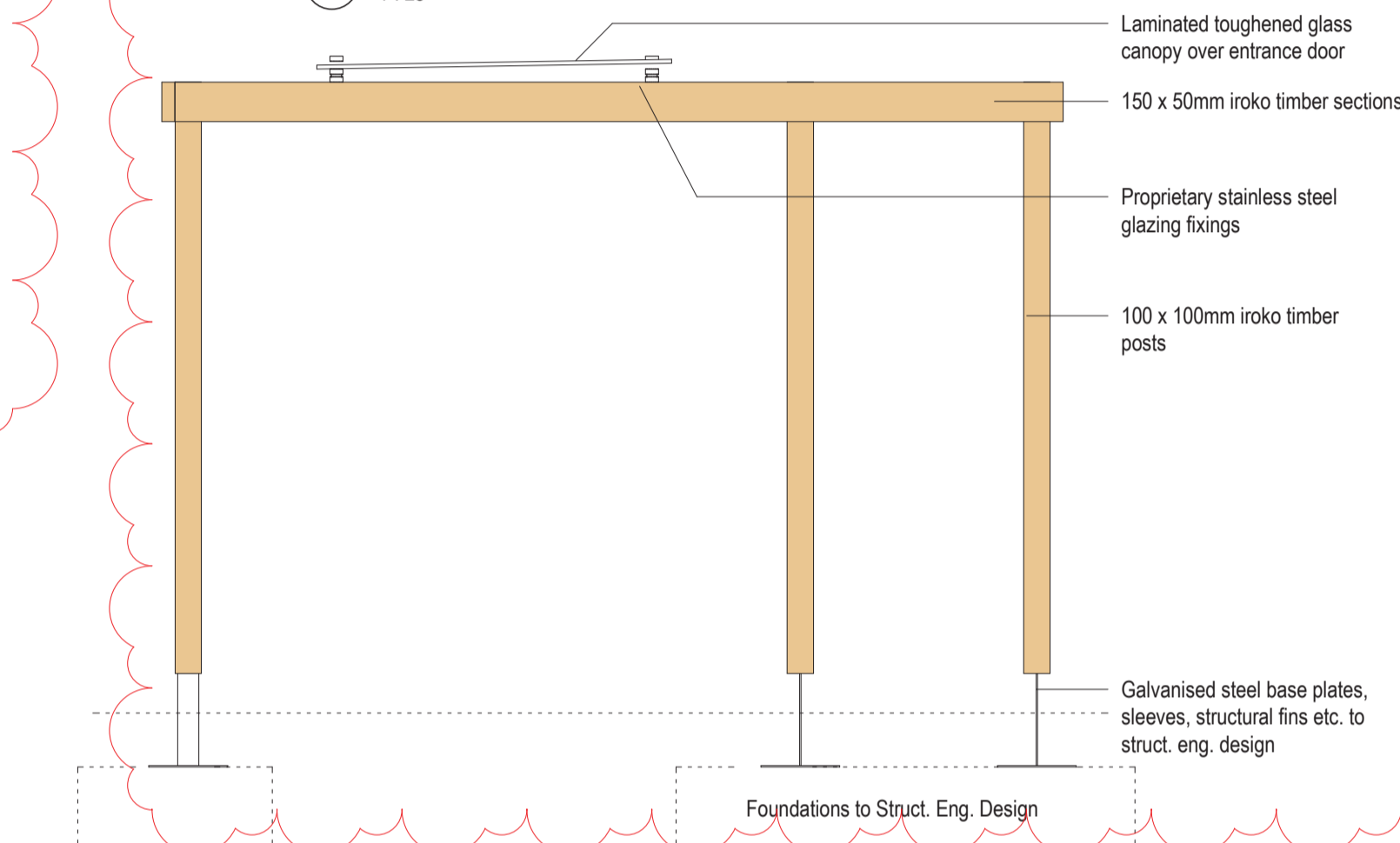

10 A2 Canopy - Elevation 2
1:25

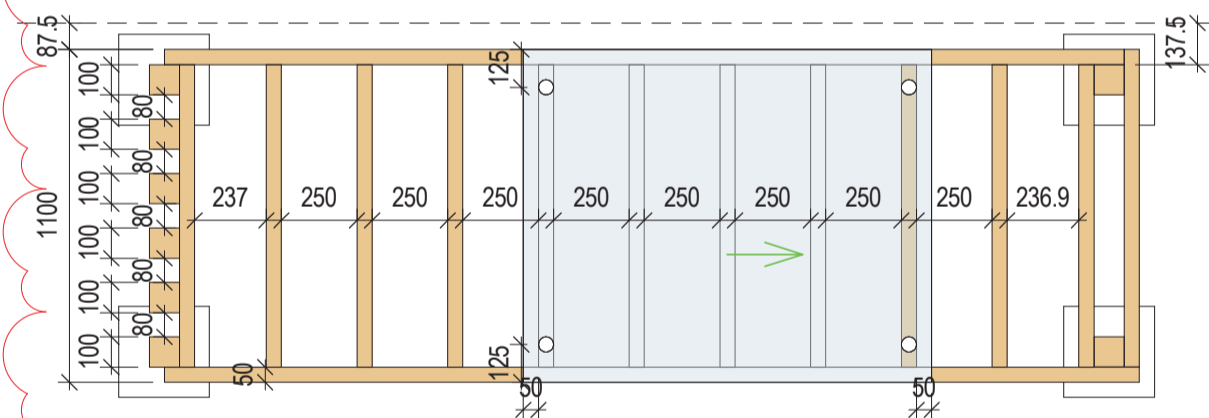

7 A1 Canopy-Roof Plan
1:25

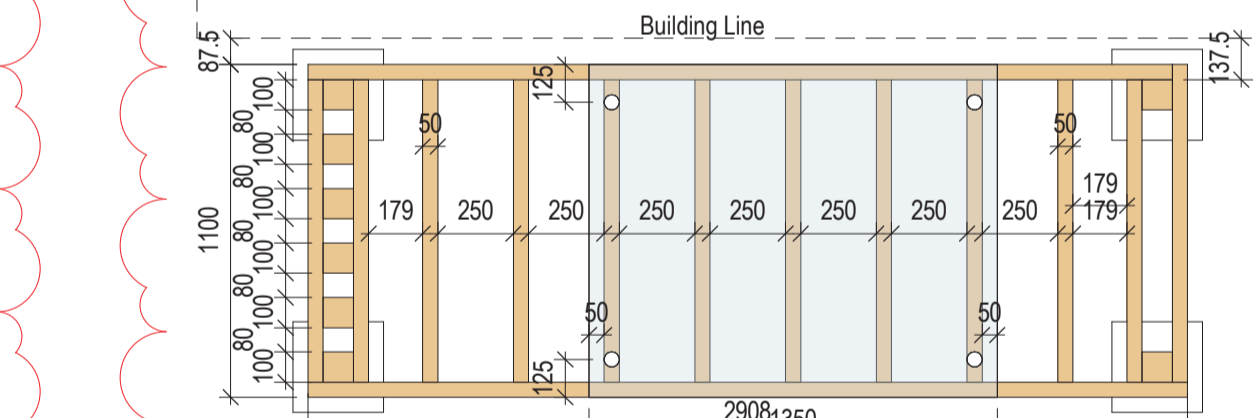

11 A3 Canopy-Roof Plan
1:25

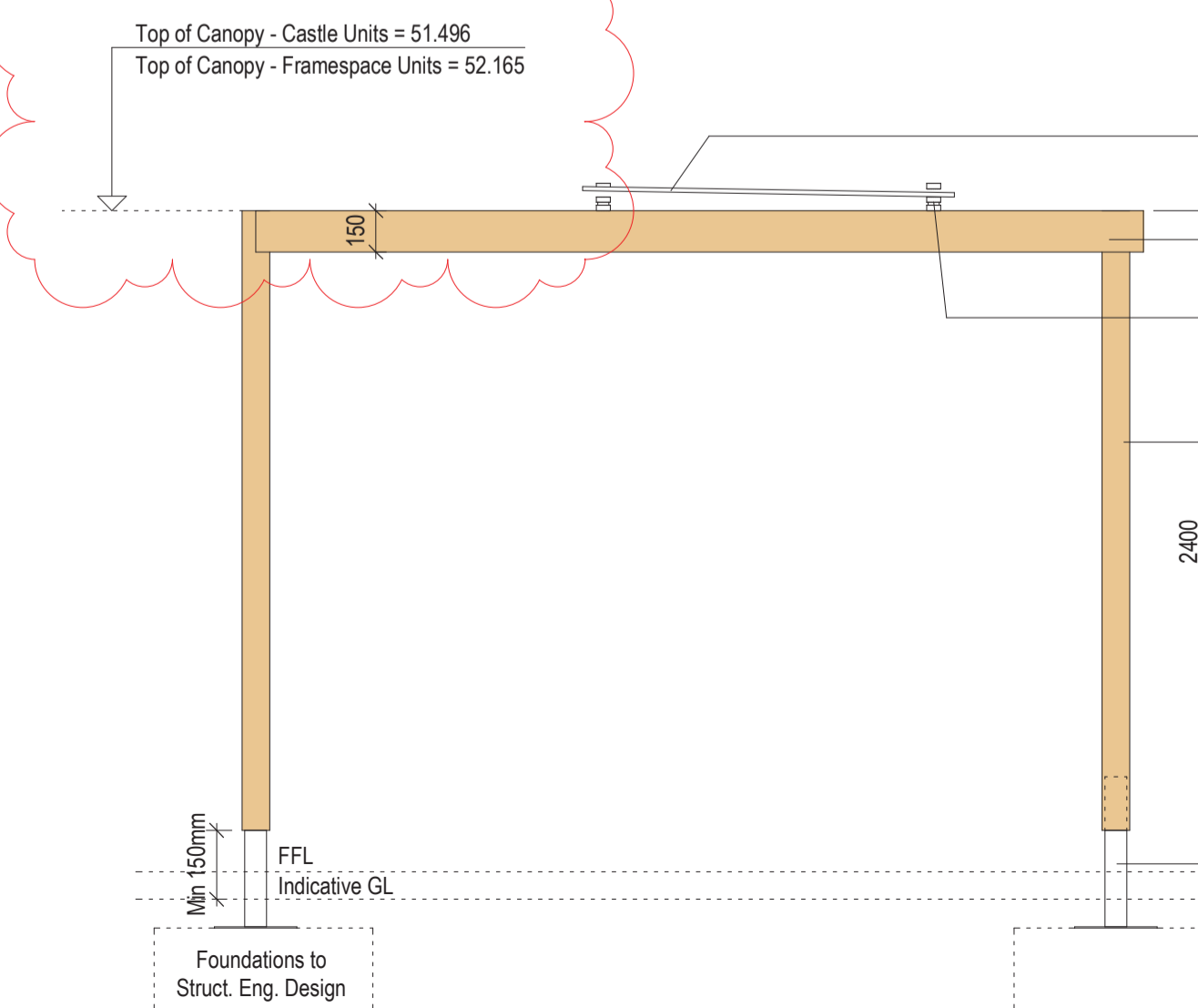

5 A1 Canopy - Elevation 1
1:25

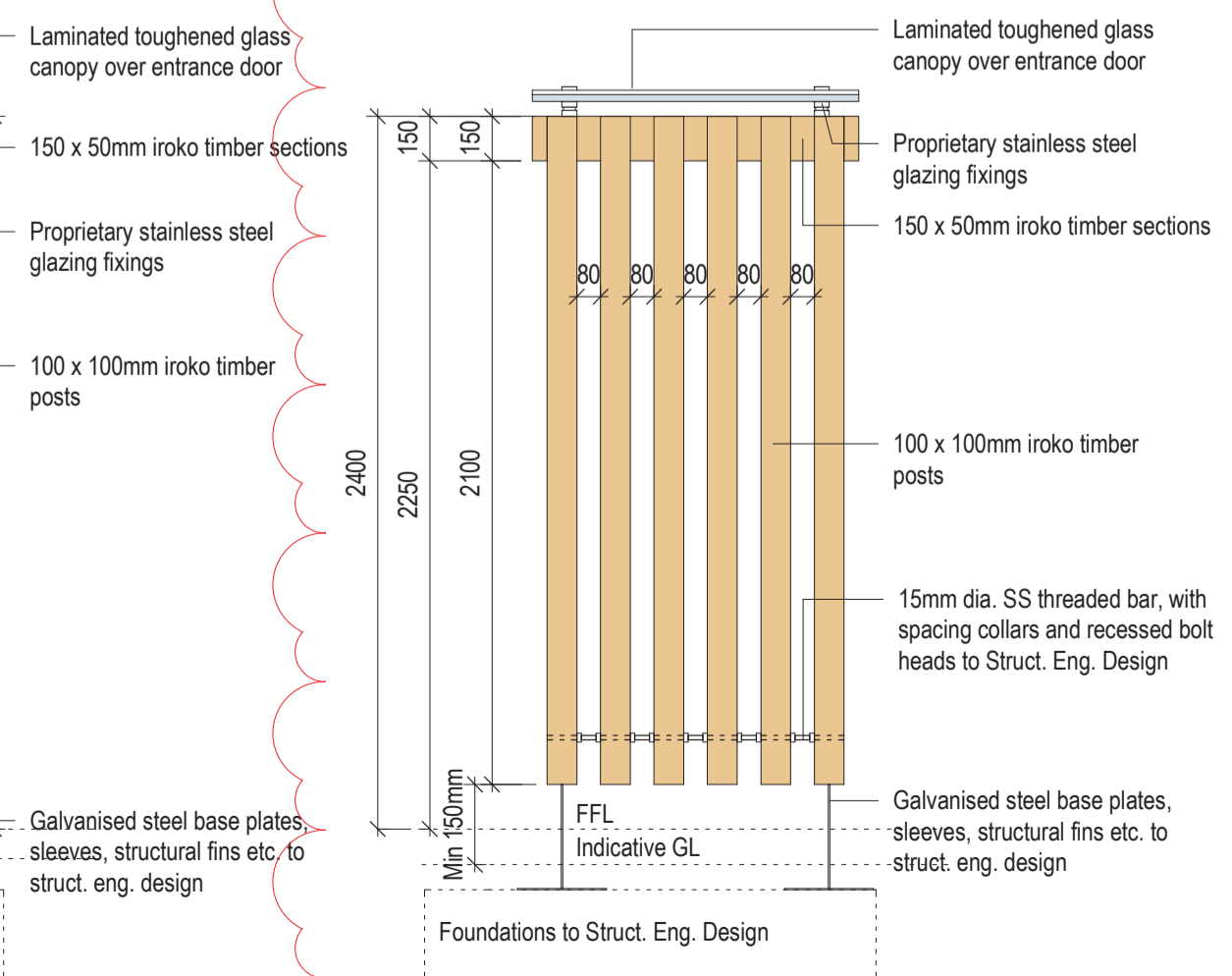

6 A1 Canopy - Elevation 2
1:25

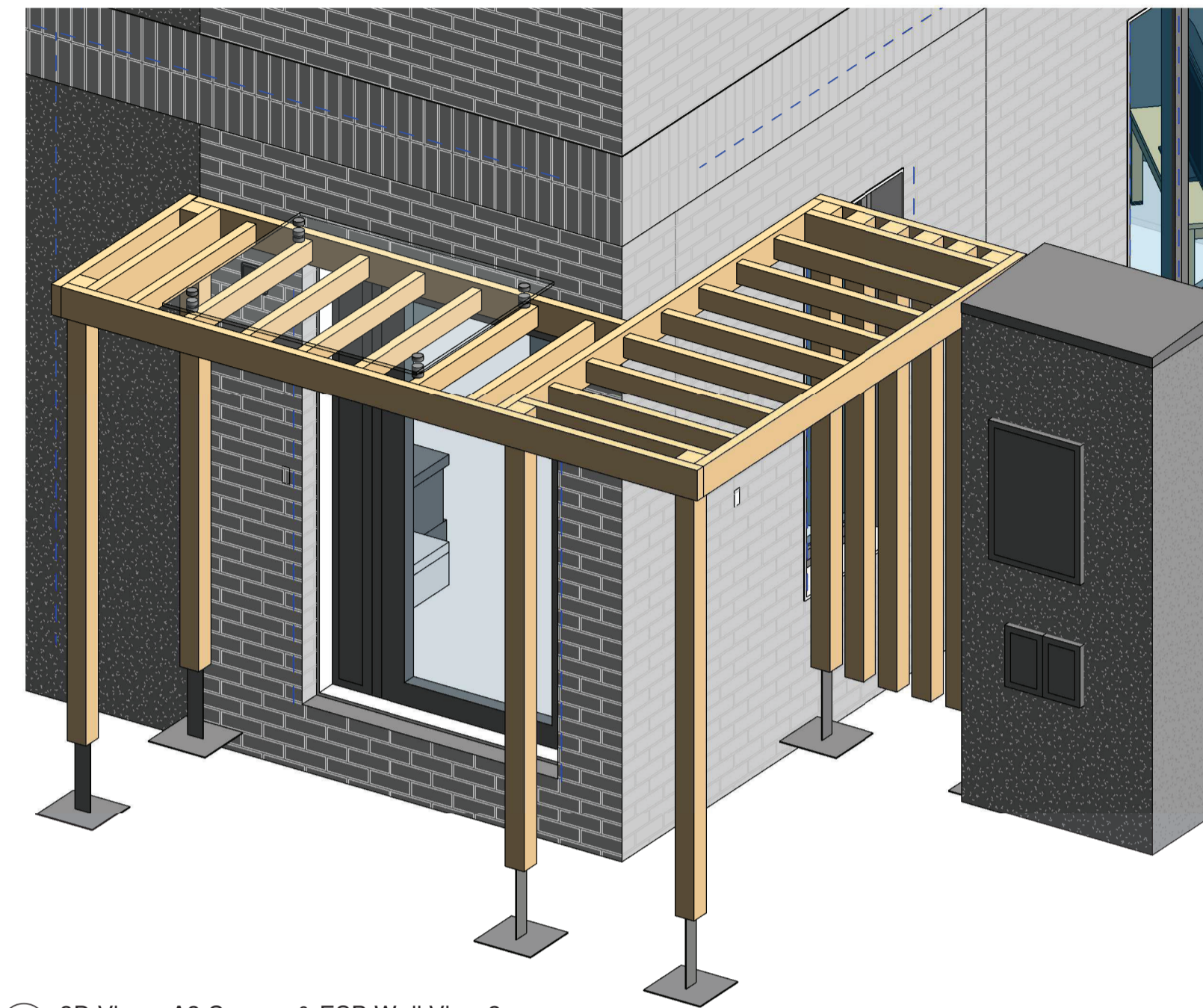

4 3D View - A2 Canopy & ESB Wall View 2
1:25

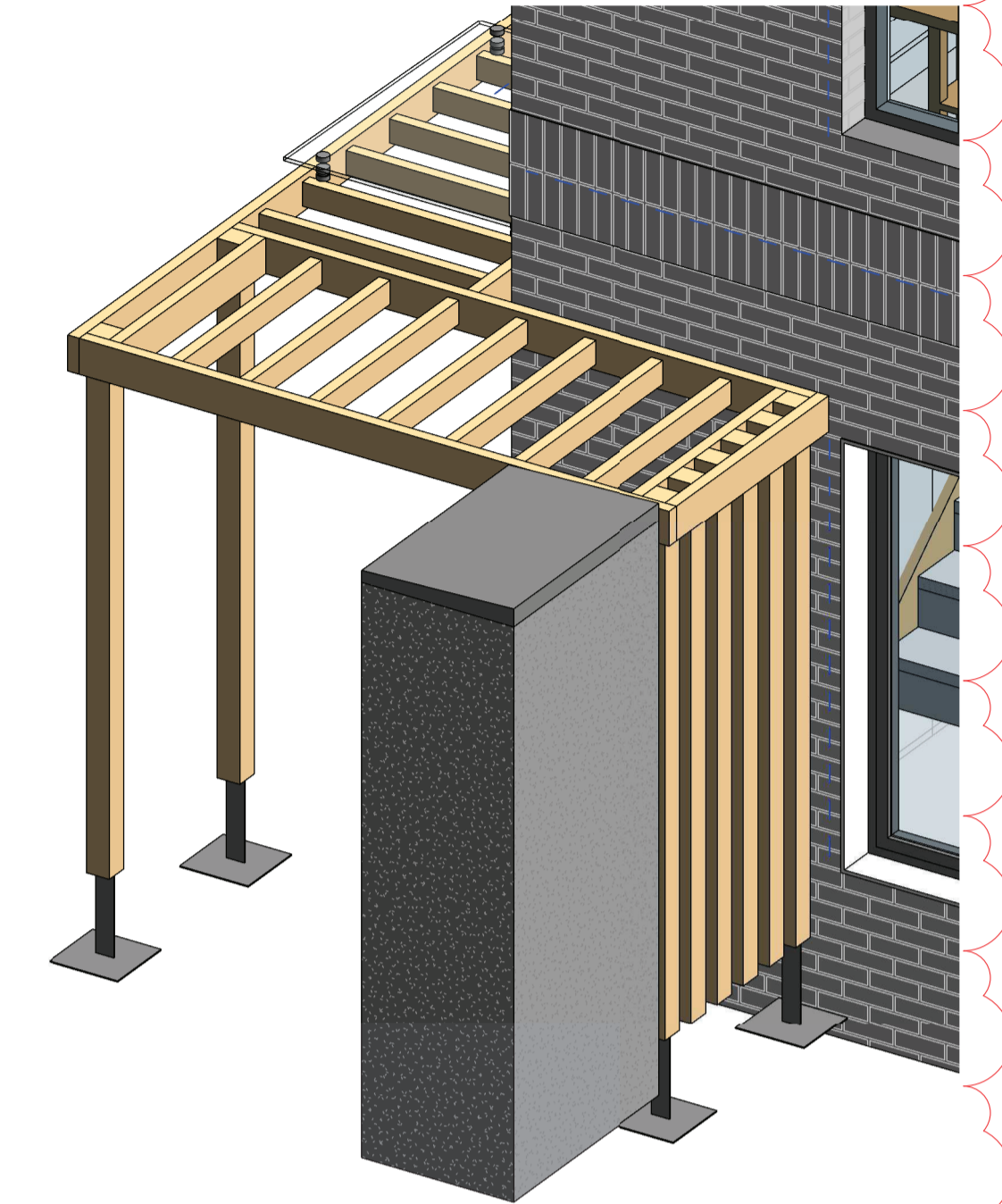

3 3D View - A2 Canopy & ESB Wall View 1
1:25

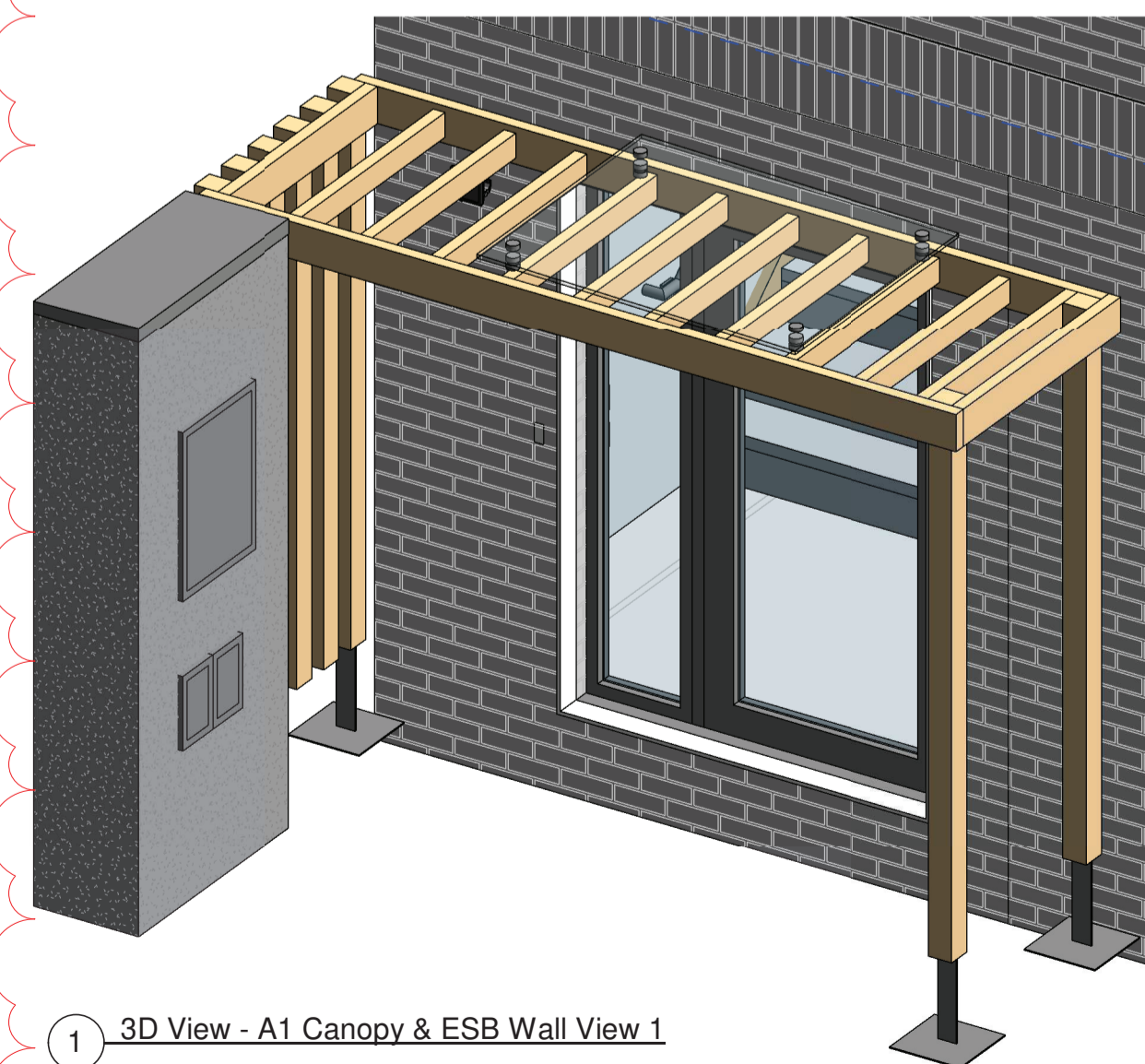

1 3D View - A1 Canopy & ESB Wall View 1
1:25

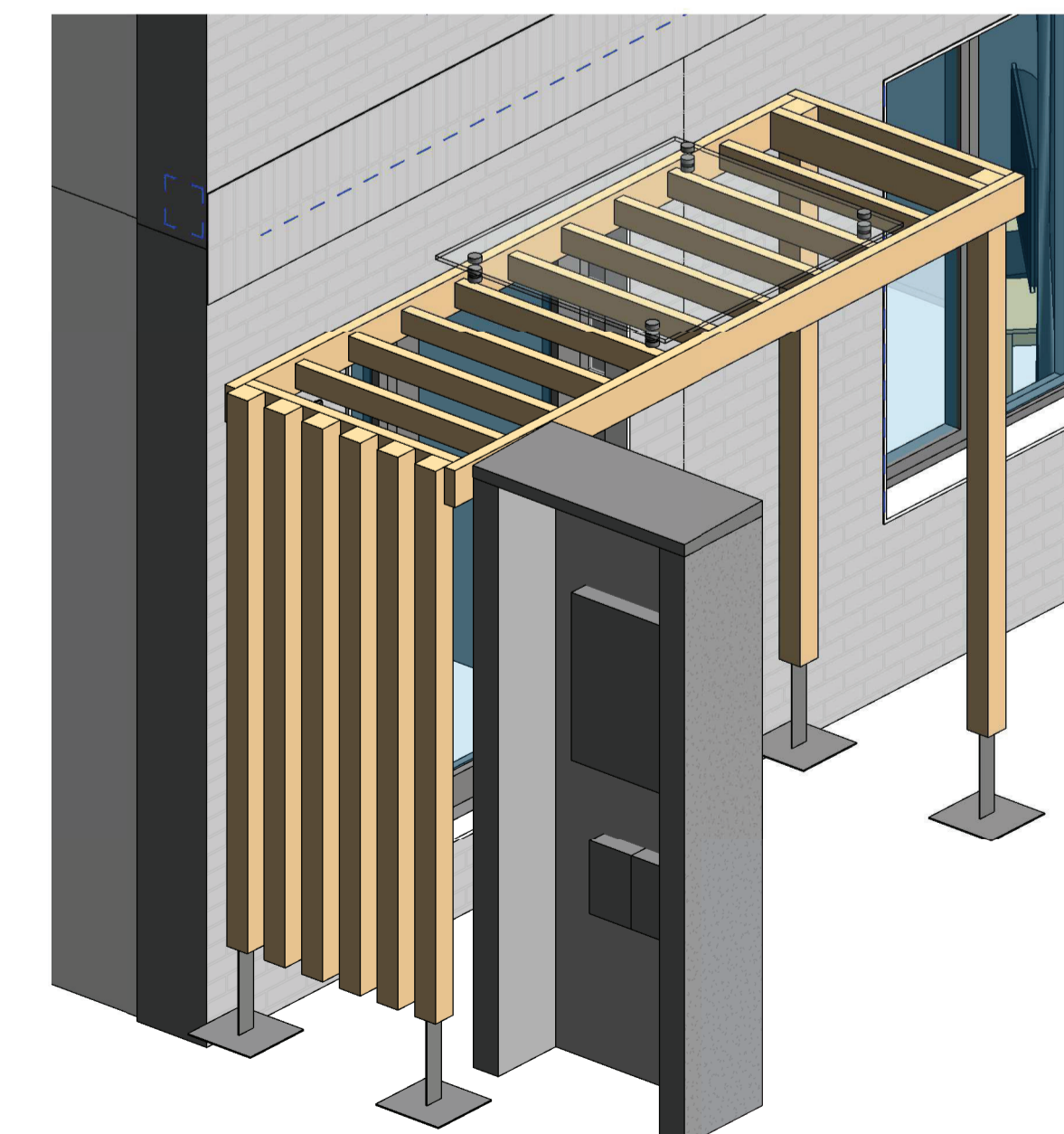

2 3D View - A1 Canopy & ESB Wall View 2
1:25

Notes:
Do not scale from this drawing.
Use figured dimensions only.
All errors and omissions to be reported to the Architect.
This drawing is to be read in conjunction with relevant consultant's drawings.
All dimensions are in millimetres and all levels are in meters to match Datums unless otherwise noted.
Contractor Design Responsibility
It is noted that there are many elements within the works that require contractor design, and will be subject to certification as part of BCAR - see Preliminary Inspection Plan for clarity on certification required.
© This drawing or design may not be reproduced without permission.

Rev	Description	Date	By
1	Issued for Information	08-08-2023	SB
2	Issued for Tender	15-08-2023	SB
3	Issued for Tender	05-09-2023	SB
4	Issued for Construction	02-11-2023	SC
5	Issued for Construction	24-11-2023	SC
6	Issued for Construction	28-11-2023	SC
7	Issued for Construction	30-11-2023	SB

Project:
OPW Ukrainian Housing - Two Storey Modular Unit
Client:
SISK

Title:
External Canopies

Drawing / Document Name:
Project Number Project Originator Volume Level Type Rate Sheet Number
2783 URMH2-COA-00-ZZ-DR-A-5055

Suitability Status : Code - Description Revision:
A4 - For Construction C-7

Scale @ A1 Drawn: Checked: Date:
As indicated Steve Burke Donal O Donoghue 08/08/23

COADY
ARCHITECTS

Mt Pleasant Business Ctr, Ranelagh, Dublin 6, D06 X7P8
Unit 8A Cran Point, Main St, Crummore, Co. Galway
01 451 6786 | 091 788 325 | admin@coady.ie | www.coady.ie

